

TORQUE WRENCH

Air Pumps
X1A1-PT
700 bar



CAUTION: This Pump should not be used for lifting applications



**AIR-POWERED
TORQUE WRENCH PUMPS**

X1A1-PT FEATURES THE SAME RUGGED TIME-PROVEN DESIGN AS THE POWER TEAM X1E1-PT

- Base pump unit, Power Team PA55 series – the standard in the industry
- Two-speed high performance pump
- Retract side internal relief-valve protects tool
- 4-way 2-position air valve standard
- External adjustable pressure regulator
- Hand remote standard

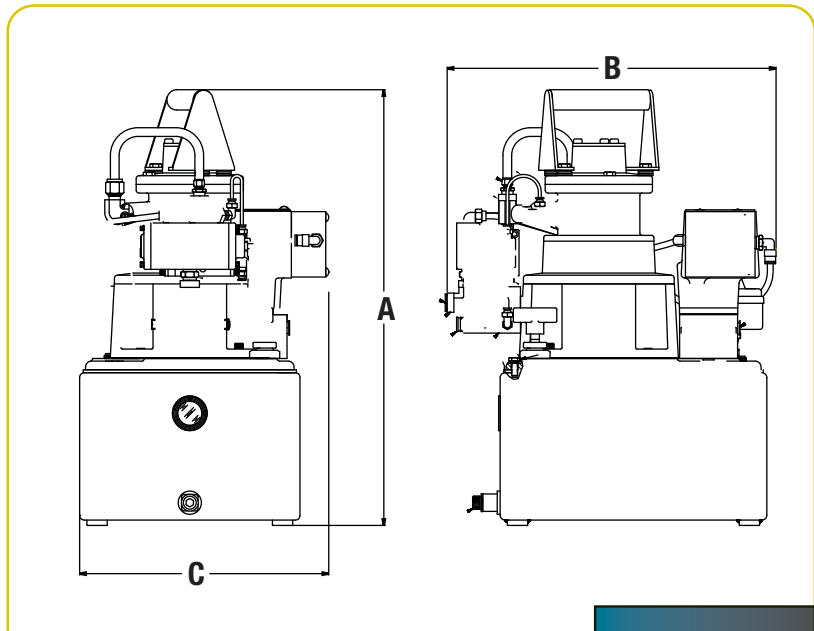

| Pump Number | Description | Oil Delivery (cu. in.) | Oil Reservoir (gal.) | A (in.) | B (in.) | C (in.) | Weight (lbs.) |
|-------------|--------------------------------|------------------------|----------------------|--------------------------------|---------|--------------------------------|---------------|
| X1A1-PT | Air-Powered Torque Wrench Pump | 55 | 2.5 | 18 ³ / ₄ | 18 | 10 ³ / ₄ | 75.0 |