

Series 3730

Type 3730-5 Electropneumatic Positioner with FOUNDATION™ fieldbus communication

SAMSON

Application

Positioners for attachment to pneumatic control valves

Valve travel from 3.6 to 300 mm · Opening angle 24 to 100°

Smart, bus-powered field device complying with FOUNDATION™ fieldbus specifications based on IEC 61158-2 transmission technology.

CE Ex
certified

The microprocessor-controlled positioner compares the reference variable cyclically transmitted over the FOUNDATION™ fieldbus network to the travel or opening angle of the control valve and issues a corresponding output signal pressure. The Type 3730-5 Positioner communicates according to FOUNDATION™ fieldbus specification with field devices, programmable logic controllers and process control systems. An integrated PID function block allows the control of process variables required directly in the field. The shift to distributed control reduces the number of control tasks to be performed by the higher-level automation system. The Link Master Capability allows autonomous closed control loops to be set up in the field.

Special features

- Integrated function blocks: 1 PID Control (PID), 1 Analog Output (AO), 1 Multiple Analog Output (MAO), 1 Multiple Analog Input (MAI), 2 Discrete Outputs (DO), 2 Discrete Inputs (DI)
- Link Master Capability
- DO function blocks to start/execute diverse functions (e.g. start the data logger)
- Two DI function blocks to analyze binary input signals
- Simple attachment to all common linear and rotary actuators
 - SAMSON direct attachment (Fig. 1)
 - NAMUR rib (Fig. 2)
 - Attachment to rod-type yokes acc. to IEC 60534-6-1
 - Attachment according to VDI/VDE 3847
 - Rotary actuator attachment according to VDI/VDE 3845 (Fig. 3)
- Any desired mounting position of the positioner (but not suspended)
- Single-knob, menu-driven operation
- Automatic start-up
- LCD easy to read in any mounted position due to selectable reading direction
- Integrated EXPERTplus diagnostics for control valves (▶ T 8389)



Fig. 1: Type 3730-5
Direct attachment to
Type 3277 Pneumatic
Actuator



Fig. 2: Type 3730-5
Attachment according
to NAMUR



Fig. 3: Type 3730-5
Attachment according to
VDI/VDE 3845

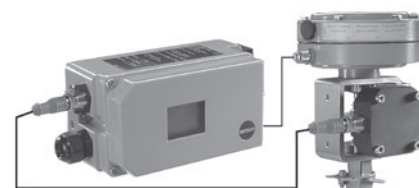

Fig. 4: Type 3730-5
External position sensor with Type 3510 Micro-flow Valve

- Classified status alarms acc. to NAMUR Recommendation NE 107
- Online changing of control parameters
- Automatic zero monitoring
- Calibrated travel sensor without gears susceptible to wear

- Permanent storage of parameters (protected against power failure)
- Adjustable output pressure limitation
- Activatable tight-closing function
- Binary input for DC voltage signals

Additional options

- Inductive limit contact with proximity switches
- Integrated solenoid valve
- Binary input for floating contact
- Leakage sensor
- External position sensor (Fig. 4)
- Stainless steel housing

Principle of operation

The positioner is mounted on pneumatic control valves and is used to assign the valve position (controlled variable x) to the control signal (set point w). The positioner compares the electric control signal of a control system to the travel or rotational angle of the control valve and issues a signal pressure (output variable y) for the pneumatic actuator.

The positioner mainly consists of an electric travel sensor system, an analog i/p module with a downstream air capacity booster and the electronics with the microcontroller. When a set point deviation occurs, the actuator is either vented or filled with air. If necessary, the signal pressure change can be slowed down with a volume restriction that can be connected as necessary. The signal pressure supplied to the actuator can be limited by software or on site to 1.4, 2.4 or 3.7 bar. The

fixed flow regulator ensures a constant air flow to the atmosphere, which is used to flush the inside of the positioner housing and to optimize the air capacity booster. The i/p module is supplied with a constant upstream pressure by the pressure regulator to compensate for any fluctuations in the supply pressure.

The positioner communicates and is powered using IEC 61158-2 transmission technology conforming to FOUNDATION™ fieldbus specification.

As a standard feature, the positioner comes with a binary input used to signalize process information over the FOUNDATION™ fieldbus network.

Operation

A single rotary pushbutton facilitates operation. The parameters are selected by turning the rotary pushbutton, pushing it activates the required setting. All parameters can be checked and changed on site. All values are displayed on the LCD. The reading direction of the LCD can be rotated by 180°. The closing direction of the control valve is indicated to the positioner by setting the DIP switch "Air to open/Air to close". It assigns the CLOSED position of the control valve to the 0 % reading. The INIT key activates initialization which is started according to the ready adjusted parameters. After initialization is completed, the positioner immediately starts closed-loop operation.

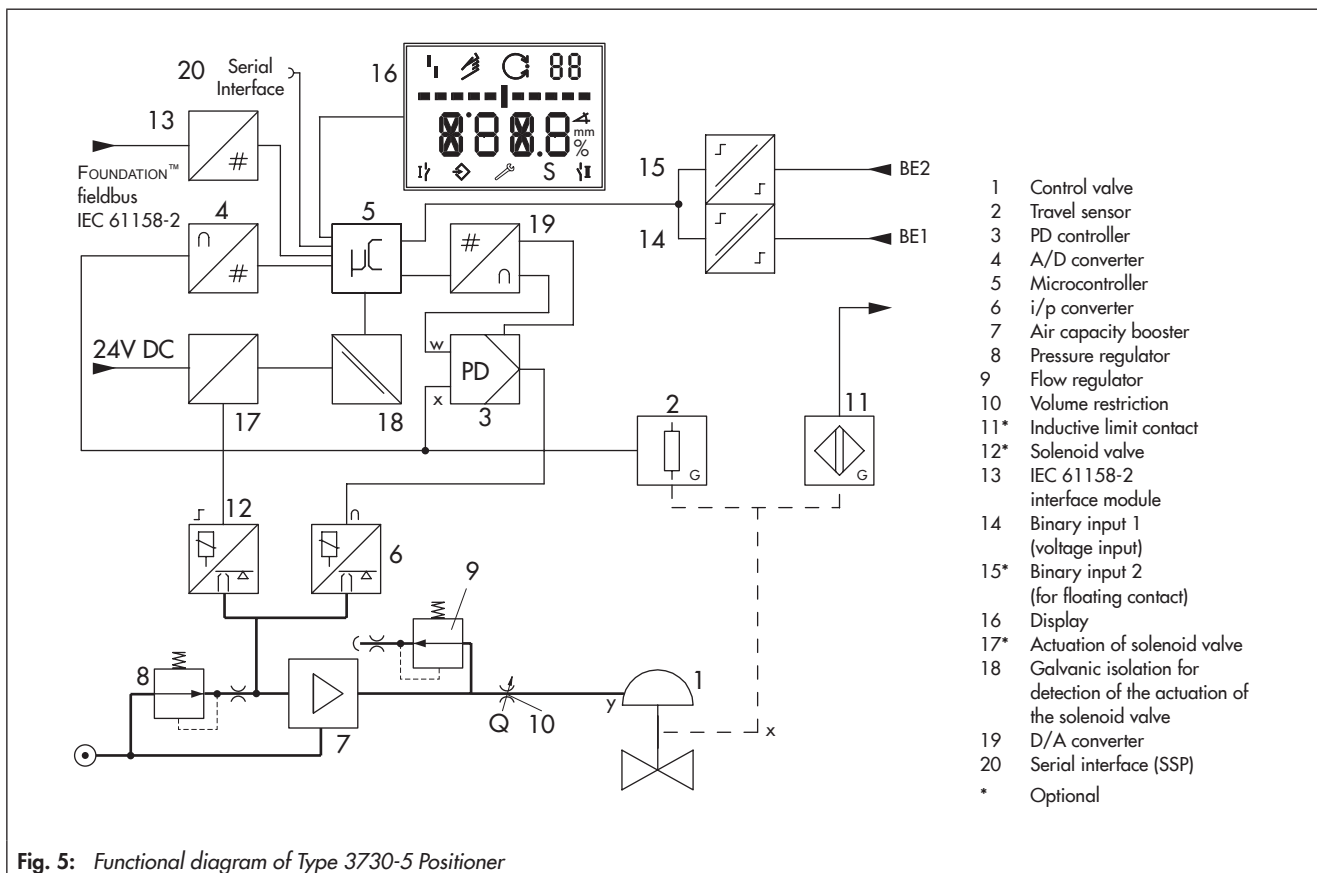











Table 1: Technical data

Type 3730-5 Positioner with FOUNDATION™ fieldbus communication	
Technical data in test certificates additionally apply to explosion-protected devices	
Rated travel	Adjustable Direct attachment to Type 3277 Actuator 3.6 to 30 mm Attachment according to IEC 60534-6 (NAMUR) 3.6 to 300 mm Attachment according to VDI/VDE 3847 3.6 to 300 mm Attachment to rotary actuators (VDI/VDE 3845) 24 to 100° opening angle
Travel range	Adjustable Adjustable within the initialized travel/angle of rotation of the valve; travel can be restricted to 1/5 at the maximum.
Bus connection	Fieldbus interface according to IEC 61158-2, bus-powered Physical Layer Class 113 (without explosion protection), 111 (explosion-protected version) Field device according to FM 3610 entity, FISCO and FNICO
Communication	Fieldbus Data transmission conforming to FOUNDATION™ fieldbus specification Communication Profile Class: 31 PS, 32 L Interoperability tested according to ITK 5.2 Baud rate: 31.25 kbit/s, twisted pair as physical layer, H1 compliance
	Execution times PID FB: 20 ms DI FB: 20 ms MAI FB: 50 ms IS FB: 30 ms AO FB: 30 ms DO FB: 30 ms MAO FB: 50 ms
	Local SAMSON SSP interface and serial interface adapter Software requirements: TROVIS-VIEW with database module 3730-5
Permissible voltage supply	9 to 32 V DC · Powered over bus line Observe the limits in the test certificate for explosion-protected versions.
Maximum operating current	15 mA
Additional current in case of error	0 mA
Supply air	1.4 to 7 bar (20 to 105 psi) Air quality acc. to ISO 8573-1: 2001 Max. particle size and density: Class 4 · Oil content: Class 3 · Humidity and water: Class 3 Pressure dew point: at least 10 K below the lowest ambient temperature to be expected
Signal pressure (output)	0 bar up to the capacity of the supply pressure
Characteristic	Linear/equal percentage/reverse equal percentage · User-defined (over operating software and communication) · Butterfly valve linear/equal percentage · Rotary plug valve linear/equal percentage · Segmented ball valve linear/equal percentage Deviation from characteristic ≤ 1 %
Hysteresis	≤0.3 %
Sensitivity	≤0.1 %
Direction of action	Reversible
Air consumption	Independent of supply air < 110 l _n /h
Air output capacity	to fill actuator with air to vent actuator At Δp = 6 bar: 8.5 m _n ³ /h · At Δp = 1.4 bar: 3.0 m _n ³ /h · K _{Vmax(20 °C)} = 0.09 At Δp = 6 bar: 14.0 m _n ³ /h · At Δp = 1.4 bar: 4.5 m _n ³ /h · K _{Vmax(20 °C)} = 0.15
Permissible ambient temperature	-20 to +80 °C (all versions) · -45 to +80 °C with metal cable gland -25 to +80 °C with inductive limit contact (SJ2-S1N) and metal cable gland The temperature limits for the explosion-protected devices may be further restricted by the limits specified in the test certificates.
Influences	Temperature ≤0.15 %/10 K
	Supply air None
	Effect of vibration ≤0.25 % up to 2 kHz and 4 g according to IEC 770
EMC	Complying with EN 61000-6-2, EN 61000-6-3, EN 61326-1 and NAMUR Recommendation NE 21
Electrical connections	One M20 x 1.5 cable gland for 6 to 12 mm clamping range · Second M20 x 1.5 threaded connection additionally exists · Screw terminals for 0.2 to 2.5 mm ² wire cross-sections
Degree of protection	IP 66/NEMA 4X
Use in safety-instrumented systems (SIL) Emergency venting at 0 V set point and using optional solenoid valve	Observing the requirements of IEC 61508, the systematic capability of the pilot valve for emergency venting as a component in safety-instrumented systems is given. Use is possible on observing the requirements of IEC 61511 and the required hardware fault tolerance in safety-instrumented systems up to SIL 2 (single device/HFT = 0) and SIL 3 (redundant configuration/HFT = 1).
Compliance	

Binary input 1	
Input	0 to 30 V DC with reverse polarity protection · Static destruction limit 40 V · Current consumption 3.5 mA at 24 V Galvanic isolation
Signal	Signal '1' at $U_e > 5 \text{ V}$ · Signal '0' at $U_e < 3 \text{ V}$
Materials	
Housing	Die-cast aluminum EN AC-ALSi12(Fe) (EN AC-44300) acc. to DIN EN 1706 · Chromated and powder paint coated · Special version: stainless steel 1.4581
External parts	Stainless steel 1.4571 and 1.4301
Cable gland	M20 x 1.5, black polyamide
Weight	Approx. 1.0 kg
Options for Type 3730-5	
Binary input 2 for floating contact	
Switching input	$R < 100 \Omega$ · Contact load 100 mA · Static destruction limit 20 V/5.8 mA · Galvanic isolation
Solenoid valve · Approval acc. to IEC 61508/SIL	
Input	24 V DC · Reverse polarity protection · Static destruction limit 40 V Power consumption: $I = \frac{U - 5.7 \text{ V}}{3840 \Omega}$ (corresponding to 4.8 mA at 24 V/114 mW)
Signal	Signal '0' no pick-up < 12 V · Signal '1' safe pick-up > 19 V (emergency venting at 0 V)
Service life	$> 5 \times 10^6$ switching cycles
Leakage sensor · Suitable for operation in hazardous areas	
Temperature range	-40 to +130 °C
Tightening torque	20 ± 5 Nm
Pepperl+Fuchs inductive limit contact	
SJ2-SN proximity switch	Measuring plate not detected: ≥ 3 mA · Measuring plate detected: ≤ 1 mA
SJ2-S1N proximity switch	Measuring plate not detected: ≤ 1 mA · Measuring plate detected: ≥ 3 mA
External position sensor	
Valve travel	Same as positioner
Cable	10 m · Flexible and durable · With M12x1 connector · Flame-retardant acc. to VDE 0472 Resistant to oils, lubricants and coolants as well as other aggressive media
Permissible ambient temperature	-60 to +105 °C with a fixed connection between positioner and position sensor · The limits in the test certificate additionally apply for explosion-protected versions
Immunity to vibration	Up to 10 g in the range of 10 Hz to 2 kHz
Degree of protection	IP 67

Table 2: Explosion protection certificates

Type	Certification			Type of protection/comments	
3730	CCoE	Number	A P HQ MH 104 1343	Ex ia IIC T6	
		Date	2013-04-19		
		Valid until	2018-04-18		
	STCC	Number	972	0Ex ia IIC T6X; 2Ex s II T6 X	
		Valid until	2017-10-01		
	-41	 EC type examination certificate	Number	PTB 04 ATEX 2109	II 2G Ex ia IIC T6; II 2D Ex tb IIIC T80°C IP66
			Date	2007-08-24	
			Number	RU-C-DE. 08.B.00697	1Ex ia IIC T6; Ex tb IIIC T80°C Db X, IP66
			Date	2014-12-15	
			Valid until	2019-12-14	
			Number	IECEx PTB 06.0054	Ex ia IIC T6
			Date	2006-11-02	
INMETRO		On request			
		Number	GYJ111267	Ex ia IIC T6	
		Date	2011-01-24		
	Valid until	2016-01-23			
-43		Number	1675804	Ex ia IIC T6; Class I , II, Div.1 , Groups A, B, C, D, E, F, G; Ex nA II T6; Ex nL IIC T6; Class I, II, Div.2, Groups A, B, C, D, E, F, G; Class II, Div.1, Groups E, F, D Type 4 Enclosure	
		Date	2006-06-01		
		Number	3023605		Class I, Zone 0 AEx ia IIC; Class I, II, III, Div.1, Groups A, B, C, D, E, F, G; Class I, Div.2, Groups A, B, C, D; Class II, Div.2, Groups F, G Type 4X
		Date	2006-03-15		
-48	 Statement of conformity	Number	PTB 05 ATEX 2010 X	II 3G Ex nA II T6; II 3G Ex ic IIC T6; II 3D Ex tc IIIC T80°C IP66	
		Date	2006-07-13		
		Number	RU-C-DE. 08.B.00697	2Ex nA ic IIC T6/T5/T4 Gc X; Ex tc IIIC T80°C Db X, IP66	
		Date	2014-12-15		
		Valid until	2019-12-14		
	Number	GYJ111268	Ex nA II T6; Ex nL IIC T6		
	Date	2011-01-24			
	Valid until	2016-01-23			

The test certificates are included in the mounting and operating instructions or are available on request.

Configuration using TROVIS-VIEW

The SAMSON configuration software, TROVIS-VIEW, can be used to configure the positioner. For this purpose, the positioner is equipped with an additional digital interface to be connected to the RS-232 interface of a PC. TROVIS-VIEW adapts the positioner to any process requirements and allows the process to be checked while the process is running. The control valve is linked to the process over the FOUNDATION™ fieldbus network. The PID function block integrated in the positioner can also be configured using TROVIS-VIEW. The configuration of the network connections for the PID function block is made by the NI-FBUS™ configurator or a corresponding digital process control system.

Network and positioner configuration with NI-FBUS™ configurator

The positioner can also be configured over the NI-FBUS™ configurator from National Instruments.

The NI-FBUS™ configurator can be used to perform the planning of the entire FOUNDATION™ fieldbus network. It also allows the use of PID controller in the positioner to implement a standalone loop in the field.

Electrical and bus connection

The Type 3730-5 Positioner with FOUNDATION™ fieldbus communication must be connected to bus segments conforming to IEC 61158-2. A shielded two-wire line is used for both supply power and data communication.

Mounting the positioner

The Type 3730 Electropneumatic Positioner can be attached directly to the Type 3277 Actuator (175 to 750 cm²) over a connection block. In actuators with “actuator stem extends” fail-safe action, the signal pressure is routed over an internal hole in the actuator yoke to the actuator. In actuators with “actuator stem retracts” fail-safe action, the signal pressure is routed to the actuator over ready-made external piping.

Using the appropriate bracket, the positioner can also be attached according to IEC 60534-6-1 (NAMUR recommendation). The positioner can be mounted on either side of the control valve.

A pair of universal brackets is used for the attachment to Type 3278 Rotary Actuators or other rotary actuators according to VDI/VDE 3845. The rotary motion of the actuator is transferred to the positioner over a coupling wheel with travel indication.

A special version of the positioner allows it to be attached according to VDI/VDE 3847. This type of attachment allows the positioner to be replaced quickly while the process is running by blocking the air in the actuator. The positioner can be attached directly to the Type 3277 Actuator using an adapter bracket or adapter block. Alternatively, it can be attached to the NAMUR rib of a control valve using an additional NAMUR connection block.

A reversing amplifier is necessary for double-acting, springless actuators for the second opposing signal pressure.

Dimensions in mm

Direct attachment

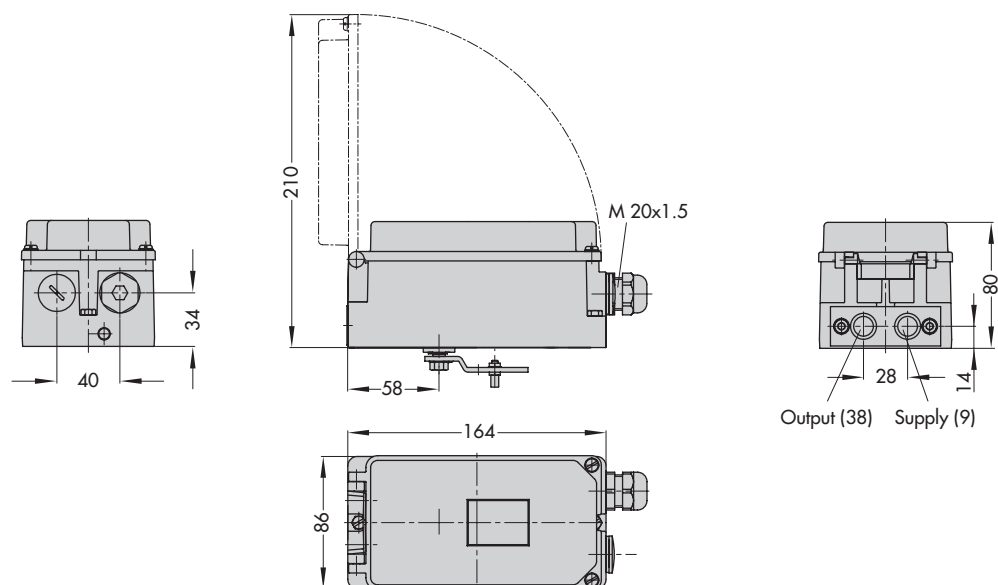

NAMUR attachment

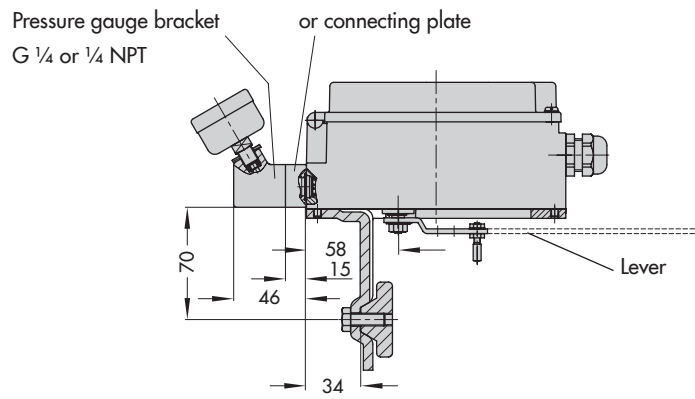

Attachment according to VDI/VDE 3847

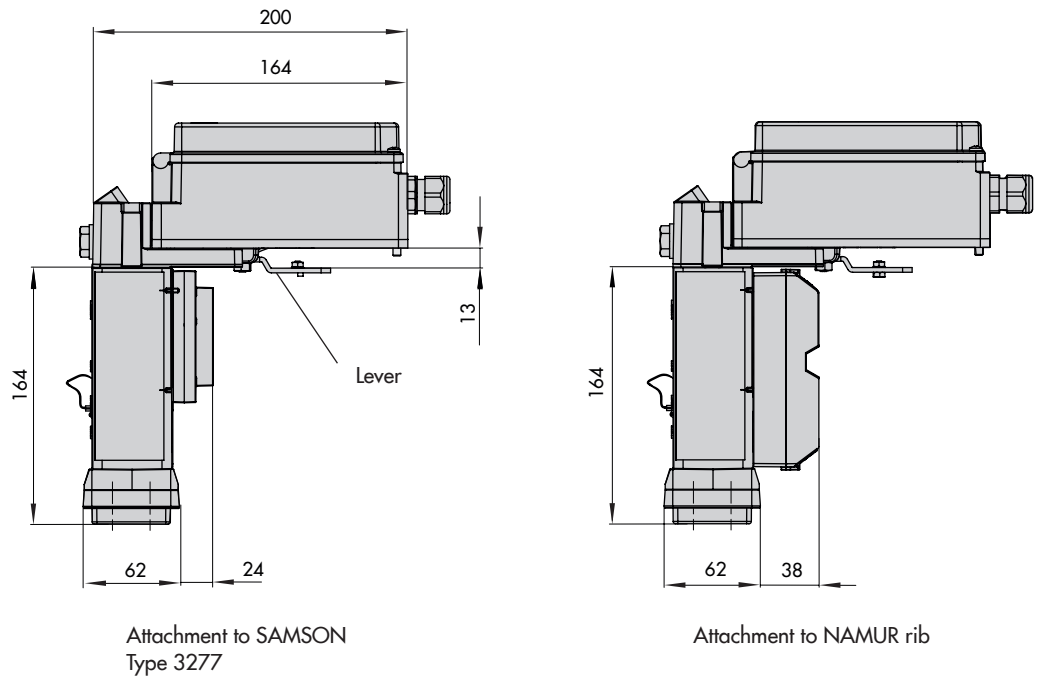

External position sensor

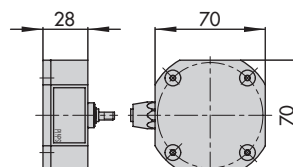

Attachment to rotary actuators

VDI/VDE 3845 (Sept. 2010)

Fixing level 1

Size AA1 to AA4

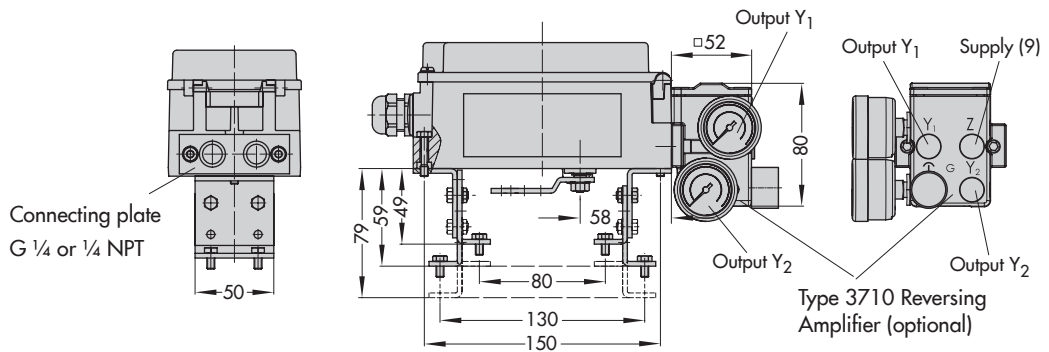

Light version

Mounting unit
CrNiMo steel bracket

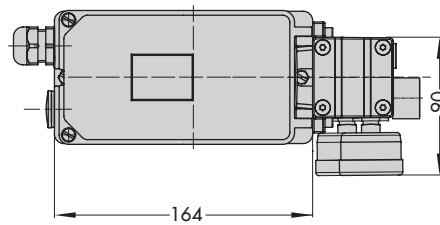

Heavy-duty version

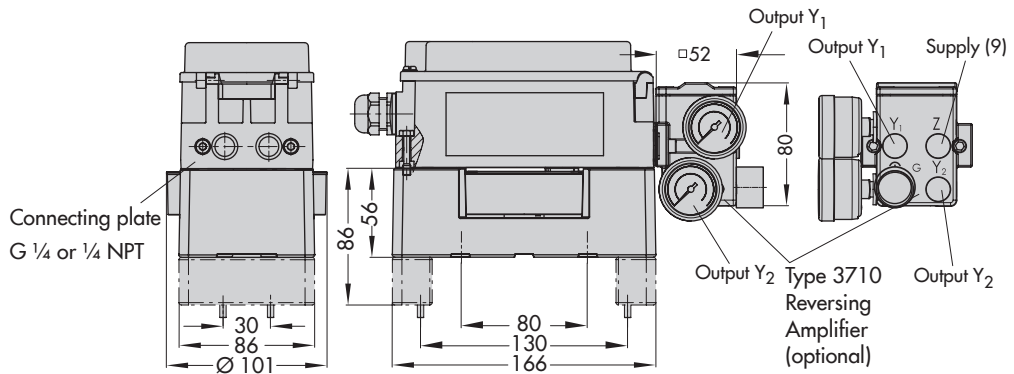

Lever

Lever	x	y	z
S	17 mm	25 mm	33 mm
M	25 mm	50 mm	66 mm
L	70 mm	100 mm	116 mm
XL	100 mm	200 mm	216 mm

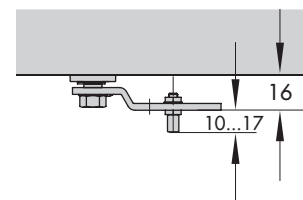
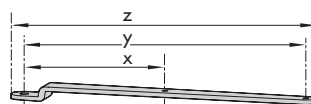

Ordering text

Type 3730-5... Positioner with FOUNDATION™ fieldbus communication

- Without pneumatic connecting rail
(only when directly attached to Type 3277)
- With pneumatic connecting rail ISO 228/1-G ¼
- With pneumatic connecting rail ¼-18 NPT
- Without/with pressure gauge up to max. 6 bar
- Attachment to Type 3277 Actuator (175 to 750 cm²)
- Attachment according to IEC 60534-6-1 (NAMUR)
Valve travel: ... mm, if applicable, rod diameter: ... mm
- Attachment according to VDI/VDE 3847
Valve travel: ... mm, if applicable, rod diameter: ... mm
- Attachment to Type 3278 Rotary Actuator (160/320 cm²),
mounting unit with CrNiMo steel bracket or heavy-duty attachment
- Attachment to rotary actuators acc. to VDI/VDE 3845,
mounting unit with CrNiMo steel bracket or heavy-duty attachment
- Pneumatic reversing amplifier for double-acting actuators
with connection acc. to ISO 228/1-G ¼ or ¼-18 NPT
- Adapter M20x1.5 to ½ NPT
- Metal cable gland
- Special version: housing made of CrNiMo steel

Article code

		x	x	x	0	x	x	x	x	0	x	0	0	x	0	x	x
Type 3730-5 Positioner																	
With LCD and autotune, FOUNDATION™ fieldbus																	
Explosion protection																	
Without		0															
ATEX II 2G Ex ia IIC T6; II 2D Ex tb IIIC T80°C IP66		1															
CSA Ex ia IIC T6; Class I, II, Div.1, Groups A, B, C, D, E, F, G; Ex nA II T6; Ex nL IIC T6; Class I, II, Div.2, Groups A, B, C, D, E, F, G; Class II, Div.1, Groups E, F, D		3															
FM Class I, Zone 0 AEx ia IIC; Class I, II, III, Div.1, Groups A, B, C, D, E, F, G; Class I, Div.2, Groups A, B, C, D; Class II, Div.2, Groups F, G																	
ATEX II 3G Ex nA II T6; II 3G Ex ic IIC T6; II 3D tc IIIC T80°C IP66		8															
Additional equipment																	
Inductive limit contact																	
Without			0														
1 x SJ2-SN (NC contact)			1														
1 x SJ2-S1N (NO contact)		0	2														
Solenoid valve																	
Without			0														
With, 24 V DC			4														
External position sensor																	
Without					0												
With		0	0		1		0			0							
Leakage sensor, FF device revision 2																	
Without							0										
With							1										
Binary input																	
Without									0								
Floating contact					0			1									
Diagnostics																	
EXPERT (standard), FF device revision 1										1							
EXPERT+ (extended diagnostics), FF device revision 1										2							
EXPERTplus (extended diagnostics), FF device revision 2										4							
Housing material																	
Aluminum (standard)											0						
Stainless steel 1.4581					0						1						
Special application																	
Without														0			
Version compatible with paint														1			
Exhaust air port with 1/4-18 NPT thread, back of positioner sealed		0	0		0		0							2			
Attachment according to VDI/VDE 3847 including interface														6			
Attachment according to VDI/VDE 3847 prepared for interface														7			
Special version																	
Without															0	0	0
NEPSI Ex ia IIC T6		1													0	0	9
NEPSI Ex nA II T6, Ex nL IIC T6		8													0	1	0
IECEX Ex ia IIC T6		1													0	1	2
GOST 1Ex ia IIC T6; Ex tb IIIC T80°C Db X, IP66		1													0	1	4
GOST 2Ex nA ic IIC T6/T5/T4 Gc X; Ex tc IIIC T80°C Db X, IP66		8													0	2	0

Specifications subject to change without notice



SAMSON AG · MESS- UND REGELTECHNIK
Weismüllerstraße 3 · 60314 Frankfurt am Main, Germany
Phone: +49 69 4009-0 · Fax: +49 69 4009-1507
samson@samson.de · www.samson.de

T 8384-5 EN

2016-06-08 · English