

Series 250

Type 3254-1 and Type 3254-7 Pneumatic Control Valves Type 3254 Globe Valve

ANSI version



Application

Control valve for process engineering applications with high industrial requirements, particularly for high pressures and temperatures

Valve size	NPS 3 to 20
Pressure rating	Class 150 to 2500
Temperatures	-325 to +1022 °F (-196 to +550 °C)



Type 3254 Globe Valve operated with

- Type 3271 Pneumatic Actuator (Type 3254-1 Control Valve)
- Type 3277 Pneumatic Actuator (Type 3254-7 Control Valve) for integral positioner attachment

Valve body made of

- Cast steel
- Cast stainless steel, high-temperature cast steel or cast cold-resisting steel
- Special materials

Low-noise valve plug

- Metal seal
- Soft seal up to Class 300
- High-performance metal seal
- Balanced to handle high differential pressures
- Additional plug stem guide in the bottom body flange

The control valves, designed according to the modular assembly principle, can be equipped with various accessories: Positioners, limit switches, solenoid valves and other accessories according to IEC 60534-6 and NAMUR recommendation (see Information Sheet ▶ T 8350 for more details).

Versions

Standard version with PTFE packing for temperatures from 14 to 428 °F (-10 to +220 °C) or with adjustable high-temperature packing from 14 to 662 °F (-10 to +350 °C), valve size NPS 3 to 20, pressure rating Class 150 to 2500 (see Table 1)

- **Type 3254-1** (Fig. 1) · Type 3254 Valve and Type 3271 Actuator with 350 to 2800 cm² actuator area (see Data Sheets ▶ T 8310-1, ▶ T 8310-2, and ▶ T 8310-3)
- **Type 3254-7** · Type 3254 Valve and Type 3277 Pneumatic Actuator with 350 to 750 cm² diaphragm area for integral positioner attachment (see ▶ T 8310-1)

Further versions

- **Welding ends or welding-neck ends** · According to ANSI B16.25
- **Flow divider or AC-1/AC-2/AC-3 Trim** for noise reduction See Data Sheets ▶ T 8081, ▶ T 8082, and ▶ T 8083
- **Valve plug with pressure balancing** · See Table 3
- **Perforated plug** · See Data Sheet ▶ T 8086

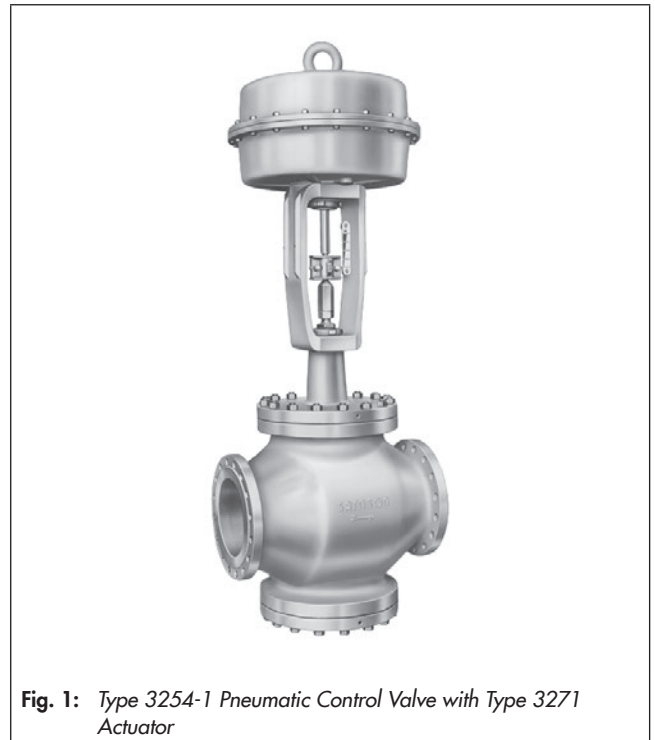

Fig. 1: Type 3254-1 Pneumatic Control Valve with Type 3271 Actuator

- **Insulating section or bellows seal** · See Technical data
- **Heating jacket** · Details on request
- **Additional handwheel** · See Data Sheet ▶ T 8310-1
- **DIN version** · DN 80 to 500, PN 16 to 400 · See Data Sheet ▶ T 8060
- **Type 3254 Valve with Type 3273 Hand-operated Actuator** For valves with max. 30 mm rated travel and side-mounted handwheel for travel > 30 mm · See Data Sheet ▶ T 8312
- **Type 3254-2 Electric Control Valve** · Details on request

Principle of operation

The medium flows through the valve in the direction indicated by the arrow. The valve plug determines the cross-sectional area of flow. The additional stem guide is located in the bottom body flange.

The version with bellows seal (Fig. 4) is fitted with a test connection to monitor the stainless steel bellows.

The valves can be equipped with a flow divider (Fig. 4, see Data Sheet ► T 8081) for noise reduction.

Pressure balancing must be used when high pressures or differential pressures act on the plug (Fig. 3).

Fail-safe position

Depending on how the springs are arranged in the pneumatic actuator (see Data Sheets ► T 8310-1, ► T 8310-2, and ► T 8310-3), the valve has two different fail-safe positions effective upon air supply failure.

- **Actuator stem extends (fail-close)**
The valve closes when the supply air fails.
- **Actuator stem retracts (fail-open)**
The valve opens when the supply air fails.

Differential pressures

The permissible differential pressures can be found in the Information Sheet ► T 8000-4.

Fig. 2 to Fig. 4 show configuration examples.

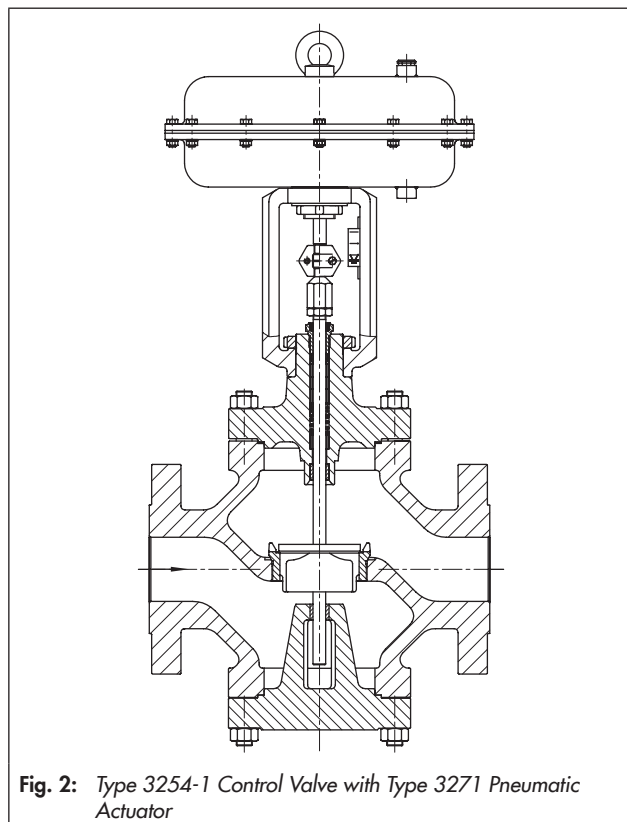

Fig. 2: Type 3254-1 Control Valve with Type 3271 Pneumatic Actuator

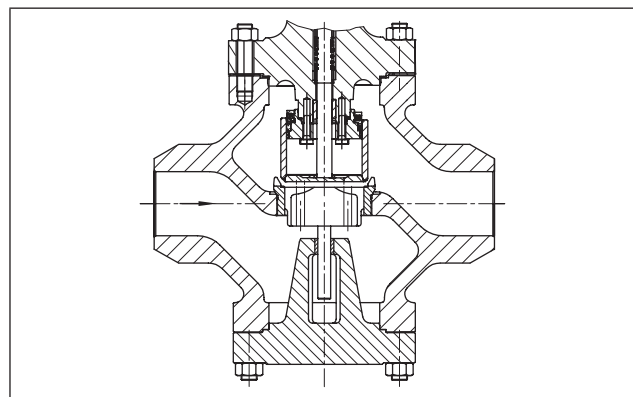

Fig. 3: Type 3254 Valve with welding ends and balanced plug

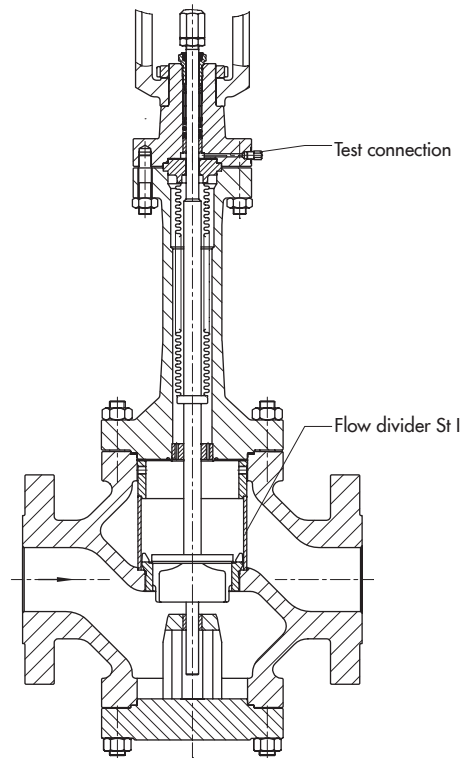

Fig. 4: Type 3254 Valve with flow divider St I and additional bellows seal with test connection

Table 1: Technical data for Type 3254

Material		Cast steel A216 WCC	Cast steel A217 WC6	Cast stainless steel A351 CF8M
Valve size and pressure rating		NPS 3 to 12 in Class 150 to 2500 NPS 16 to 20 in Class 150 to 1500		
Type of connection	Flanges	All ANSI versions		
	Welding ends	According to ANSI B16.25		
Seat-plug seal		Metal seal · Soft seal · High-performance metal seal		
Characteristic		Equal percentage · Linear · Quick opening (see Information Sheet ► T 8000-3)		
Rangeability		50:1		
Compliance		CE · EAC		
Temperature ranges in °F (°C) · Permissible operating pressures according to pressure-temperature diagrams (see Information Sheet ► T 8000-2)				
Body without insulating section		14 to 428 (-10 to +220) · Up to 662 (350) with high-temperature packing		
Body with insulating section or bellows seal		-20 to +800 (-29 to +427)	-20 to +932 (-29 to +500)	-325 to +1022 (-196 to +550)
Valve plug ¹⁾	Standard	Metal seal	-325 to +1022 (-196 to +550) ²⁾	
		Soft seal	-325 to +428 (-196 to +220) ²⁾	
	Balanced with PTFE ring	-58 to +428 (-50 to +220) ³⁾		
	Balanced with graphite ring	428 to +1022 (220 to +550)		
Leakage class according to ANSI/FCI 70-2				
Valve plug	Standard	Metal seal	Standard: IV · High-performance metal seal: V	
		Soft seal	VI	
	Balanced, metal seal	With PTFE ring: IV · With graphite ring: III		

¹⁾ Only in combination with suitable body material

²⁾ Note: The temperature limits are not directly converted temperatures.

³⁾ Lower temperatures on request

Table 2: Materials

Standard version Body and flanges ¹⁾		Cast steel A216 WCC	Cast steel A217 WC6	Cast stainless steel A351 CF8M
Valve bonnet		A216 WCC/A 105	A217 WC6/A182 F12 Cl. 2	A351 CF8M/A 182 F316
Seat and plug ²⁾ Seal ring for	Metal seal	410-2/1.4008		316 L/CF3M
	Soft seal	PTFE with 15 % glass fiber		
	Pressure balancing	PTFE with carbon · Graphite		
Guide bushings		1.4112		2.4610
Packing ³⁾		V-ring packing: PTFE with carbon, spring: 302 or high-temperature packing		
Body gasket		Graphite seal on metal core		
Insulating section		A216 WCC/A 105	A217 WC6/A 182 F12 Cl.2	A351 CF8M/A 182 F316
Metal bellows seal				
Intermediate piece		A216 WCC/A 105	A217 WC6/A 182 F12 Cl.2	A217 WC6/A182 F12
Metal bellows		1.4571 ⁴⁾		
Heating jacket		1.4541		

¹⁾ Other materials (e.g. for high-temperatures or low temperatures) as well as special materials for applications with sea water, such as 1.4538, duplex 1.4470, nickel-based alloy 9.4610, see pressure-temperature diagrams in Information Sheet ► T 8000-2

²⁾ Seats and metal-seated plug also with Stellite® facing or plug made of solid Stellite® available (up to max. K_{VS} 630)

³⁾ Other packings on request (see Information Sheet ► T 8000-1)

⁴⁾ Other bellows materials on request

Table 3: Available C_V coefficients · Versions highlighted in gray also available with balanced plug

Terms for control valve sizing according to IEC 60534, Parts 2-1 and 2-2: $F_L = 0.95$, $X_T = 0.75$

Table 3.1: Overview with flow divider St I ($C_{V I}/K_{VS I}$), St II ($C_{V II}/K_{VS II}$), and St III ($C_{V III}/K_{VS III}$)

C_V		75	120	190	290	420	735	1150	1730	2300	2900	4200
K_{VS}		63	100	160	250	360	630	1000	1500	2000	2500	3600
$C_{V I}$		67	105	170	265	375	650	1040	1560	2080	2600	3700
$K_{VS I}$		57	90	144	225	320	560	900	1350	1800	2250	3200
$C_{V II}$		60	95	145	235	335	580	950	1400	1860	2300	–
$K_{VS II}$		50	80	125	200	290	500	800	1200	1600	2000	–
$C_{V III}$		55	90	140	220	315	560	880	1280	1730	2200	–
$K_{VS III}$		47	75	120	190	270	480	750	1100	1500	–	–
Seat \varnothing	in	2.48	3.15	3.94	4.92	5.91	7.87	9.84	11.81	13.78	15.75	19.69
	mm	63	80	100	125	150	200	250	300	350	400	500
Rated travel	in	1.18			2.36			4.72				
	mm	30			60			120				

Table 3.2: Versions without flow divider · Class 150 to 2500

C_V		75	120	190	290	420	735	1150	1730	2300	2900	4200
K_{VS}		63	100	160	250	360	630	1000	1500	2000	2500	3600
NPS	DN											
3	80	•	• ¹⁾									
4	100	•	•	• ¹⁾								
6	150	•	•	•	•	• ¹⁾						
8	200		•	•	• ²⁾	•	• ¹⁾					
10	250		•	•	• ²⁾	•	•	• ¹⁾				
12	300			•	• ³⁾	•	•	•	• ¹⁾			
16	400					•	•	•	•	•	• ¹⁾	
20	500							•	•	•	•	• ¹⁾
1) Reduced C_V/K_{VS} coefficients with Class 900 to 2500:	C_V	105	170	–	375	650	1040	1560	–	2600	3700	
	K_{VS}	90	144	–	320	560	900	1350	–	2250	3200	

1) Pressure balancing only for \geq Class 600

2) Pressure balancing only for Class 600/900

Table 3.3: Versions with flow divider St I · Class 150 to 900¹⁾

$C_{V I}$		67	105	170	265	375	650	1040	1560	2080	2600	3700
$K_{VS I}$		57	90	144	225	320	560	900	1350	1800	2250	3200
NPS	DN											
3	80	•	•									
4	100	•	•	•								
6	150	•	•	•	•	•						
8	200		•	•	• ²⁾	•	•					
10	250		•	•	• ²⁾	•	•	•				
12	300			•	• ³⁾	•	•	•	•			
16	400					•	•	•	•	•	•	
20	500							•	•	•	•	•

1) Class 1500 to 2500 with flow divider St I and pressure balancing on request

2) Pressure balancing only for \geq Class 600

3) Pressure balancing only for Class 600/900

Table 3.1: Overview with flow divider St I (C_{vI}/K_{vSI}), St II (C_{vII}/K_{vSII}), and St III (C_{vIII}/K_{vSIII})

C_v		75	120	190	290	420	735	1150	1730	2300	2900	4200
K_{vS}		63	100	160	250	360	630	1000	1500	2000	2500	3600
C_{vI}		67	105	170	265	375	650	1040	1560	2080	2600	3700
K_{vSI}		57	90	144	225	320	560	900	1350	1800	2250	3200
C_{vII}		60	95	145	235	335	580	950	1400	1860	2300	–
K_{vSII}		50	80	125	200	290	500	800	1200	1600	2000	–
C_{vIII}		55	90	140	220	315	560	880	1280	1730	2200	–
K_{vSIII}		47	75	120	190	270	480	750	1100	1500	–	–
Seat Ø	in	2.48	3.15	3.94	4.92	5.91	7.87	9.84	11.81	13.78	15.75	19.69
	mm	63	80	100	125	150	200	250	300	350	400	500
Rated travel	in	1.18			2.36			4.72				
	mm	30			60			120				

Table 3.4: Versions with flow divider St II · Class 150 to 900 ¹⁾

C_{vII}		60	95	145	235	335	580	950	1400	1860	2300	–
K_{vSII}		50	80	125	200	290	500	800	1200	1600	2000	–
NPS	DN											
3	80	•	•									
4	100	•	•	•								
6	150	•	•	•	•	•						
8	200		•	•	• ²⁾	•	•					
10	250		•	•	• ²⁾	•	•	•				
12	300			•	• ³⁾	•	•	•	•			
16	400					•	•	•	•	•	•	
20	500							•	•	•	•	

¹⁾ Class 1500 to 2500 with flow divider St II and pressure balancing on request

²⁾ Pressure balancing only for \geq Class 600

³⁾ Pressure balancing only for Class 600/900

Table 3.5: Versions with flow divider St III · Class 150 to 900 ¹⁾

C_{vIII}		55	90	140	220	315	560	880	1280	1730	2200	–
K_{vSIII}		47	75	120	190	270	480	750	1100	1500	1900	–
NPS	DN											
4	100	•										
6	150	•	•	•	•							
8	200		•	•	• ²⁾	•						
10	250			•	• ²⁾	•	•					
12	300			•	• ³⁾	•	•	•				
16	400					•	•	•	•	•		
20	500							•	•	•	•	

¹⁾ Class 1500 to 2500 with flow divider St III and pressure balancing on request

²⁾ Pressure balancing only for \geq Class 600

³⁾ Pressure balancing only for Class 600/900

Table 4: Dimensions for Type 3254-1 and Type 3254-7 Pneumatic Control Valves in standard version

Table 4.1: Type 3254 Valve · Face-to face dimensions according to ANSI/ISA-75.08.01 for Class 600 and lower and according to ASME B16.10 for Class 900 and higher

Valve		NPS	3	4	6	8	10	12	16	20	
		DN	80	100	150	200	250	300	400	500	
Length L (flanges RF and welding ends)	Class 150	in	11.75	13.88	17.75	21.38	26.50	29.00	40.00	49.88 ⁵⁾	
		mm	298	352	451	543	673	737	1016	1267 ⁵⁾	
	Class 300	in	12.50	14.50	18.62	22.38	27.88	30.50	41.62	51.50 ⁵⁾	
		mm	318	368	473	568	708	775	1057	1308 ⁵⁾	
	Class 600	in	13.25	15.50	20.00	24.00	29.62	32.25	43.62	54.02 ⁵⁾	
		mm	337	394	508	610	752	819	1108	1372 ⁵⁾	
	Class 900	in	15.00	18.00	24.00	29.00	33.00	38.00	44.50	On request	
		mm	381	457	610	737	838	965	1130		
	Class 1500	in	18.50	21.50	27.75	32.75	39.00	44.50	54.50	On request	
		mm	470	546	705	832	991	1130	1384		
	Class 2500	in	22.75	26.50	36.00	40.25	50.00	56.00	-		
		mm	578	673	914	1022	1270	1422			
Height H4	Class 150 to 600	in	8.74	9.53	12.37	15.24	17.41 ¹⁾	25.79	25.20	32.28	
		mm	222	242	314	387	442 ¹⁾	655	640	820	
	Class 900	in	8.74	9.53	12.37	15.24	20.43 ²⁾	25.79	On request	On request	
		mm	222	242	314	387	519 ²⁾	655			
	Class 1500 to 2500	in	11.34	13.7	17.56	22.44	On request	On request	On request ³⁾	On request ³⁾	
		mm	288	348	446	570					
H8 for actuator	350 cm ²	in	9.45	9.45	-						
		mm	240	240							
	355 cm ²	in	9.45	9.45	16.46	-	-	-			
		mm	240	240	418						
	700 cm ²	in	9.45	9.45	16.46	16.46	16.46	-			
		mm	240	240	418	418	418				
	750 cm ²	in	9.45	9.45	16.46	16.46	16.46	-			
		mm	240	240	418	418	418				
	1000 cm ²	in	11.61	11.61	16.46	16.46	On request				
		mm	295	295	418	418					
	1400-60 cm ²	in	11.61	11.61	16.46	16.46	On request	On request			
		mm	295	295	418	418					
	1400-120 cm ²	in	18.90	18.90	19.80	19.80	19.80	25.59	25.59	25.59	
		mm	480	480	503	503	503 ⁴⁾	650	650	650	
2800 cm ²	in	18.90	18.90	19.80	19.80	19.80	25.59	25.59	25.59		
	mm	480	480	503	503	503 ⁴⁾	650	650	650		
2x2800 cm ²	in	18.90	18.90	19.80	19.80	19.80	25.59	25.59	25.59		
	mm	480	480	503	503	503 ⁴⁾	650	650	650		
H2	Class 150	in	6.89	8.15	11.34	15.35	16.14	18.90	22.05	24.80	
		mm	175	207	288	390	410	480	560	630	
	Class 300 to 600	in	8.74	9.80	13.31	15.35	16.14	18.90	25.59	28.94	
		mm	222	249	338	390	410	480	650	735	
	Class 900	in	8.74	9.80	13.31	15.35	16.14	18.90	On request		
		mm	222	249	338	390	410	480			
	Class 1500	in	11.02	12.24	17.40	20.87	26.77	29.92	On request		
		mm	280	311	442	530	680	760			
	Class 2500	in	11.02	13.11	17.72	On request					
		mm	280	333	450						

¹⁾ NPS 10 in Class 150 to 300:
442 mm/17.40 in

²⁾ NPS 10 in Class 600 to 900:
519 mm/20.43 in

³⁾ Class 1500

⁴⁾ H8 = 650 mm with 250 mm seat bore

⁵⁾ Face-to-face dimensions according to SAMSON standard

Dimensional drawings

Type 3271 Pneumatic Actuator

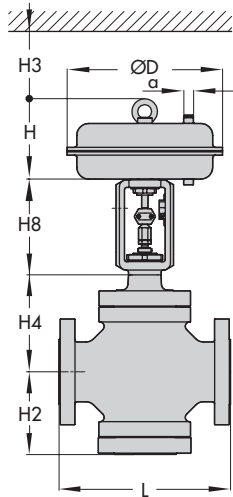

Type 3254-1

Type 3277 Pneumatic Actuator

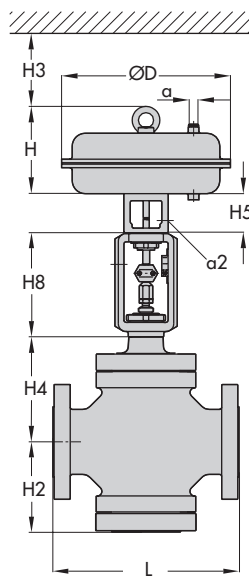

Type 3254-7

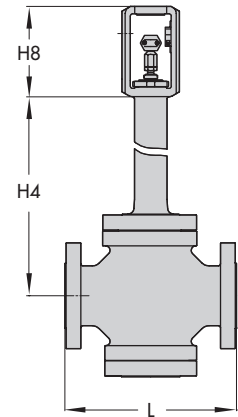

Type 3254 with bellows seal or insulating section

Table 4.2: Types 3271 and 3277 Pneumatic Actuators

Actuator area	cm ²	350	355	700	750	1000	1400-60	1400-120	2800	2 x 2800
Diaphragm ØD	in	11.02	11.02	15.35	15.51	18.19	20.87	21.02	30.32	30.32
	mm	280	280	390	394	462	530	534	770	770
H ¹⁾	in	3.23	4.76	7.83	9.29	15.87	11.3	19.29 ^{3)/} 22.83 ⁴⁾	24.80 ^{3)/} 27.36 ⁴⁾	44.49 ^{3)/} 47.05 ⁴⁾
	mm	82	121	199	236	403	287	490 ^{3)/} 580 ⁴⁾	630 ^{3)/} 695 ⁴⁾	1130 ^{3)/} 1195 ⁴⁾
H3 ²⁾	in	4.33	4.33	7.48	7.48	24.02	24.02	25.59	25.59	25.59
	mm	110	110	190	190	610	610	650	650	650
H5	Type 3277 in	3.98	3.98	3.98	3.98	-	-	-	-	-
	Type 3277 mm	101	101	101	101	-	-	-	-	-
Thread	Type 3271	M30 x 1.5				M60 x 1.5		M100 x 2		
	Type 3277	M30 x 1.5				-	-	-	-	-
a	Type 3271	G 3/8 (3/8 NPT)	G 3/8 (3/8 NPT)	G 3/8 (3/8 NPT)	G 3/8 (3/8 NPT)	G 3/4 (3/4 NPT)	G 3/4 (3/4 NPT)	G 1 (1 NPT)	G 1 (1 NPT)	G 1 (1 NPT)
a2	Type 3277	G 3/8	G 3/8	G 3/8	G 3/8	-	-	-	-	-

¹⁾ Height with welded-on lifting eyelet or height of eyebolt according to DIN 580. Height of the swivel lifting hook may differ. Actuators up to 355 cm² without lifting eyelet

²⁾ Minimum clearance required to remove the actuator

³⁾ Height for version with welded-on lifting eyelet (material EN-JS1030)

⁴⁾ Height for version with female thread (material 1.5638/A352 LC3)

Table 5: Weights for Type 3254-1 and Type 3254-7 in standard version

Table 5.1: Type 3254 Valve

Valve	NPS	3	4	6	8	10	12	16	20	
	DN	80	100	150	200	250	300	400	500	
Weight for valve without actuator	Class 150	lbs	130	179	410	948	2138	2381	4255	On request
		kg	59	81	186	430	970	1080	1930	
	Class 300	lbs	196	287	785	948	2138	2381	4255	On request
		kg	89	130	356	430	970	1080	1930	
	Class 600	lbs	196	287	785	1323	2509	3417	6173	On request
		kg	89	130	356	600	1138	1550	2800	
	Class 900	lbs	196	287	785	1415	3009	3902	6834	On request
		kg	89	130	356	642	1365	1770	3100	
	Class 1500	lbs	On request							
		kg								
		lbs								
		kg								
Class 2500	lbs	On request								
	kg									

Table 5.2: Types 3271 and 3277 Pneumatic Actuators

Actuator		cm ²	350	355	700	750	1000	1400-60	1400-120	2800	2 x 2800
Type 3271 (approx.)	Without handwheel	lbs	18	33	49	80	187	154	386	992	2094
		kg	8	15	22	36	85	70	175	450	950
	With handwheel	lbs	29	44	60	91	419	386	661 ¹⁾ /937 ²⁾	1268 ¹⁾ /1543 ²⁾	On request
		kg	13	20	27	41	190	175	300 ¹⁾ /425 ²⁾	575 ¹⁾ /700 ²⁾	On request
Type 3277 (approx.)	Without handwheel	lbs	26	42	57	88	-	-			
		kg	12	19	26	40					
	With handwheel	lbs	37	53	68	98	-				
		kg	17	24	31	45					

¹⁾ Side-mounted handwheel up to 80 mm travel

²⁾ Side-mounted handwheel above 80 mm travel

Table 6: Dimensions and weights for the standard version of Type 3254 with insulating section - Without actuator

Valve size	NPS	3	4	6	8	10	12	16	20		
	DN	80	100	150	200	250	300	400	500		
Height H4	Class 150 to 600	in	19.37	20.16	26.18	37.28	42.01	45.32	44.76	On request	
		mm	492	512	665	947	1067	1151	1137		
	Class 900	in	19.37	20.16	26.18	37.28	42.01	On request			
		mm	492	512	665	947	1067				
	Class 1500 to 2500	in	21.5	23.54	31.10	42.13	On request		Class 1500 On request		
		mm	546	598	790	1070					
Weight without actuator for	Class 150	lbs	174	223	454	1045	2271	2476	4350	On request	
		kg	79	101	206	474	1030	1123	1973		
	Class 300	lbs	240	331	829	1045	2271	2476	4350		
		kg	109	150	376	474	1030	1123	1973		
	Class 600	lbs	240	331	829	1420	2641	3512	6268		
		kg	109	150	376	644	1198	1593	2843		
	Class 900	lbs	240	331	829	1512	3201	3997	6929		
		kg	109	150	376	686	1452	1813	3143		
	Class 1500 to 2500	lbs	On request						Class 1500 On request		
		kg	On request						Class 1500 On request		

Table 7: Dimensions and weights for the standard version of Type 3254 with bellows seal · Without actuator

Valve size		NPS	3	4	6	8	10	12	16	20	
		DN	80	100	150	200	250	300	400	500	
		Travel									
Height H4	Class 150	0.59" to 2.36"	24.13	24.13	27.72						
			613	613	704						
	Class 300 to 900	15 to 60 mm	24.13	24.13	32.96						
			613	613	837						
	in	0.59	34.02	On request							
		mm	15			864					
	Class 1500	in	1.18	34.02	On request						
			mm	30			864				
	in	2.36	-		On request						
		mm					60				
	Class 2500	in	0.59	40.16	On request						
			mm	15			1020				
	in	1.18	40.16	On request							
		mm	30			1020					
	in	2.36	-		On request						
		mm					60				
	Class 150 to 300	in	1.18 to 4.72	-			41.22	59.13	60.20	59.69	62.60
			mm				30 to 120	1047	1502	1529	1516
	Class 600 to 900	in	1.18 to 2.36	-			62.24	62.68	64.96	On request	
			mm				30 to 60	1581	1592		
Class 600	in	4.72	-			-	94.65	91.42	90.16	On request	
		mm				120	2404	2322	2290		
Weight for valve with bellows seal (without actuator) for	Class 150	lbs	190	247	474	1146	2370	2575	4453	On request	
		kg	86	112	215	520	1075	1168	2020		
	Class 300	lbs	262	353	882	1146	2370	2575	4453		
		kg	119	160	400	520	1075	1168	2020		
	Class 600	lbs	262	353	882	1521	2745	3616	6371		
		kg	119	160	400	690	1245	1640	2890		
	Class 900	lbs	262	353	882	1609	3307	4101	7033		
		kg	119	160	400	730	1500	1860	3190		
	Class 1500	lbs	On request								On request
		kg									-
	Class 2500	lbs	On request								-
		kg									-

Selection and sizing of the control valve

1. Calculate the C_v (K_v) coefficient according to IEC 60534-6.
2. Select valve size NPS and C_v (K_{vs}) coefficient from Table 3.
3. Determine the permissible differential pressure from the Information Sheet ► T 8000-4.
4. Select the valve body material from Table 1 and Table 2 as well as from the pressure-temperature diagrams (see Information Sheet ► T 8000-2).
5. Select accessories from Table 1 and Table 2.

Order specifications:

Valve size	NPS
Pressure rating	Class
Body material	According to Table 2
Bonnet	Standard bonnet, insulating section or bellows seal
Type of connection	Flanges/welding ends
Plug	Standard or balanced Soft seal, metal seal or high-performance metal seal
Characteristic	Equal percentage, linear or quick opening
Actuator	Type 3271 or Type 3277 (see Data Sheets ► T 8310-1, ► T 8310-2, and ► T 8310-3)
Fail-safe position	Fail-close or fail-open
Process medium	Density in lb/cu.ft or kg/m ³ and temperature in °F (°C)
Flow rate	lbs/h or kg/h or cu.ft/min or m ³ /h in standard or operating state
Pressure	p_1 and p_2 in psi (bar) (absolute pressure p_{abs}) (with minimum, normal and maximum flow rate)
Valve accessories	Positioner and/or limit switch

Note: The temperature limits for DIN and ANSI versions are not directly converted temperatures.

Specifications subject to change without notice



SAMSON AG · MESS- UND REGELTECHNIK
Weismüllerstraße 3 · 60314 Frankfurt am Main, Germany
Phone: +49 69 4009-0 · Fax: +49 69 4009-1507
samson@samson.de · www.samson.de

T 8061 EN

2015-12-17 · English