

FUNCTION AND PURPOSE

This spring-loaded, dual-acting pressure and vacuum relief vent provides much needed protection from a dangerous build-up of positive and negative forces, known as pressure and vacuum, on tank trailers transporting hazardous chemicals.

Each vent is carefully assembled and tested to each customers' exact specifications.

Careful attention was paid to the design around the idea of a minimization of repair parts and a vent which could be easily disassembled with simple hand tools.

Disassembly

Our patented design can be disassembled using our T-wrench feature. (See page 6) This feature effectively "traps" the spring and reduces the internal pressure enough to allow easy separation of the valve housings. The main wearable parts are exposed, facilitating the cleaning and repair. The vent can be returned to service within minutes.

MATERIALS OF CONSTRUCTION

All metallic parts	Stainless Steel (316L)
"O" Ring	Teflon® encapsulated silicone
Gasket	Teflon®

PERFORMANCE SPECIFICATIONS (3" Design)

MAWP	TEST PRESSURE	FLOW (SCFH)	EXPOSED SURFACE
25	40	372,844	732
25	45	408,485	860
30	45	408,485	860
35	52.5	460,443	1061

PERFORMANCE SPECIFICATIONS (4" Design)

MAWP	TEST PRESSURE	FLOW (SCFH)	EXPOSED SURFACE
25	40	374,512	737
25	45	431,308	946
30	45	431,308	946
35	52.5	484,718	1156

Vacuum Performance

3,726 SCFH AT 6" HG (EQUIVALENT TO 584 GPM)
INSTANT OPENING AT 4" HG



DOT 3X407T and DOT407LT

Weight: 11 lbs.

Installed Height: 5 1/4" over the top of the pipe nipple

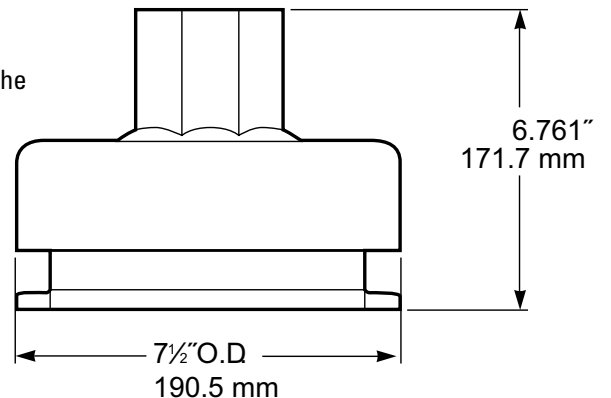

Parts And Ordering Information

