

MODEL 2171 BACK PRESSURE / RELIEF REGULATOR

The Model 2171 is a stainless steel back pressure/relief regulator designed to handle small to mid-capacity flow rates in general, chemical or cryogenic services. This unit is capable of controlling inlet pressure to setpoint levels between 5 and 500 psig (.34 and 20.6 Barg).



FEATURES

- High Stability:** High mass plug allows dampening of high frequency disturbances from inlet or outlet side of regulator.
- Trim Removal:** Easily removable trim from valve while in-line by removing screwed-on spring chamber.
- Trim Selections:** Seven different trim combinations for metallic or composition seated designs.
- Flow-thru Angle Design:** Two side inlet ports; Bottom outlet port.
- Globe Design 1/2" Size:** One side inlet port; one side outlet port.

APPLICATIONS

Designed to control a wide range of fluids including industrial gases, air, oil, steam, water and many chemicals. See Table 1 for more information. Available for cryogenic service and NACE applications.



CAUTION

This is not a safety device and must not be substituted for a code approved pressure safety relief valve or rupture disc.

STANDARD/GENERAL SPECIFICATIONS

Body Size / End Connection: 1/4", 3/8", 1/2" (DN8, 10,15) NPT.
Angle Design: with thru-body connections (2 side inlets; bottom outlet).
Globe Design: 1/2" only - side inlet, side outlet. No bottom connection.
Opt-30: 1/2" x 150# or 300# RF Angle -Two connection; side inlet, bottom outlet. (Plugged third connection.)
Opt-34: 1/2"x 150# or 300# RF Globe-Two connection; side inlet, side outlet.

Body Material: Standard: Wrought Barstock; ASTM A479, Type 316L stainless steel.

Spring Chamber: Cast Bronze: ASTM B62, Alloy C83600.
SST: ASTM A351, Grade CF3M 302 SST.

Diaphragms: See Table 5.

Trims: SST; metallic seated or composition seated. See Table 5.

Gasket/Seal: TFE diaphragm gasket with metal diaphragms; TFE o-ring at pressure plate locations.
Alternate Material: See Opt-45.

Operating Temperatures: Standard: -20 to +400°F (-29° to +205°C). See Tables 2 and 5.
Cryogenic: See Option -36.

Inlet Pressure: Standard: Up to 300 psig (20.7 Barg); includes limitation of 100 psi (6.9 Bar) pressure build when set at 200 psig (13.8 Barg) under low flow rate. See Table 2.
Optional: Up to 600 psig (41.3 Barg) (including build) when Option-80 specified.

Maximum Pressure Drop: Metal Seat: 600 psid (41.3 Bard).
Composition Seat: 400 psid (27.6 Bard).

Range Springs & Max. Pressure Build: Standard: Epoxy coated steel.
Cryogenic: SST.

Steel Range Spring		Maximum Build ¹			SST Range Spring		Maximum Build
psig	(Barg)	%	psid	(Bard)	psig	(Barg)	%
5-30	(.34-2.1)	50	--	--	5-30	(.34-2.1)	20
20-80	(1.4-5.5)	50	--	--	20-80	(1.4-5.5)	20
70-140	(4.8-9.6)	50	--	--	70-140	(4.8-9.6)	20
130-200	(9.0-13.8)	50	100	(6.9)	130-200	(9.0-13.8)	20
Option -80							
190-300	(13.1-20.7)	50	100	(6.9)			
270-400	(18.6-27.6)	39	100	(6.9)			
360-500	(24.8-34.5)	29	100	(6.9)			

¹ The lesser of the % or psid (Bard) values must be used as the limit. Build percentage is with respect to setpoint value.

Cv's/Capacities: See Tables 4, 5, 6 and 7.

OPTION SPECIFICATIONS

Option-2: HANDWHEEL. Plastic handwheel on standard unit; aluminum handwheel for Opt. -2+80. Utilize for frequent setpoint changes.

Option-20: DOME LOADING. Spring chamber and range spring replaced by bronze dome for external pressure loading up to 100 psig (6.9 Barg); 1/4" (DN8) NPT loading connection. Max. capacity = 0.5 Cv.

Option-22: PANEL MOUNTING. Includes a mounting nut and a handwheel. Figure 1.

Option-25: VENT TAP. Spring chamber vent tapped 1/8" (DN6) NPT for remote venting.

Option-25S: VENT SCREEN. Cap (For Opt-25).

Option-30: FLANGED END CONNS. Welded-on 150# and 300# raised face flanged for 1/2" (DN15) body size ONLY. Flanges and nipples of same basic material. Nipples and Flanges are socket weld design. Two connections only.

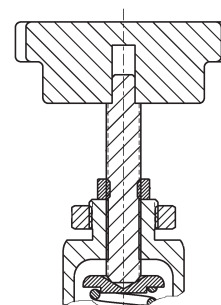

Figure 1: Option -22 Panel Mounting (handwheel portion is same for Option -2 Handwheel) Spring Chamber Thread 3/4" - 16 UNF-2A

With 150# or 300# flanges, the flange pressure rating is the limiting factor for inlet rating, not the body inlet rating.

With 150# flanges, the flange pressure rating is the limiting factor for outlet rating, not the body inlet rating. With 300# flanges, the body outlet rating is the limiting factor.

Option-34: SPECIAL 14" FACE TO FACE DIMENSION FOR FLANGED END CONNECTIONS. Globe Design - Sizes 1/2" only. See Opt.-30 for standard face to face dimension, angle design.

Option-36: CRYOGENIC SERVICE. Includes SST body and spring chamber. All wetted internal parts are of SST materials suitable for cryogenic service. The range spring, adjusting screw and locknut are SST; the spring button and pressure plate are brass. TFE/SST spring loaded seal for diaphragm and pressure plate. Cleaned per Cashco Spec. #S-1134. **Suitable for cryogenic fluids from -325°F to +100°F (-198° to +38°C).** The spring chamber has a 1/8" (DN6) NPT female connection for purge gas plus a 1/8" (3.2 mm) drilled drain hole. Mount in horizontal piping with the adjusting screw oriented downwards. Suitable for inlet setpoint pressures up to 200 psig (13.8 Barg).

Option-40SST: SST NACE CONSTRUCTION. Internal wetted portions meet NACE standard MR0175 when the exterior of the regulator is not directly exposed to a sour gas environment, buried, insulated or otherwise denied direct atmospheric exposure. 316 SST body/spring chamber material only. S3, S7 and S8 only trim selections available. Not available with Option -20 or -80.

Option-45: TFE GASKETS. Primarily for oxygen service. Limits temperature range to -20° to +400°F (-29° to +205°C).

Option-55: SPECIAL CLEANING. Cleaned per Cashco Spec. #S-1134 for oxygen service. **NOTE:** Design Pressure Rating shall not exceed 375 psig (25.8 Barg) when process medium is oxygen.

Option-56: SPECIAL CLEANING. Cleaned per Cashco Spec. #S-1542. Utilize when cleanliness level better than normal is required and unit is NOT FOR OXYGEN SERVICE.

Option-80: HIGH INLET PRESSURE. For controlling inlet pressure above 200 psig (13.8 Barg) setpoint; allows 100 psi (6.9 Bar) maximum pressure build above the setpoint. Available in aluminum bronze and SST spring chamber.

Option-85: INLET GAUGE TAP. 1/4" (DN8) NPT female connection on side of body for inlet pressure, for incorporation of gauge. Gauge not included.

Option-86: INLET PRESSURE GAUGE. Glycerine filled pressure gauge. SST case, bourdon tube, socket, and movement. 2-1/2" (65 mm) dial size. Service application temperature range of 30 to +160°F (-1 to +71°C) maximum. Rear case 1/4" (DN8) male NPT connection. Dual range scales of psig and Bar. Includes Option-85 body gauge tap when specified. **DO NOT SPECIFY WITH OPTIONS -36 OR -55.**

Spring Range		Nominal ¹ Gauge Range	
psig	(Barg)	psig	(Barg)
5-30	(.34-2.1)	0-55	(0-4)
20-80	(1.4-5.5)	0-140	(0-10)
70-140	(4.8-9.6)	0-220	(0-16)
130-200	(9.0-13.8)	0-350	(0-25)
190-300	(13.1-20.7)	0-550	(0-40)
270-400	(18.6-27.6)	0-550	(0-40)
360-500	(24.8-34.5)	0-850	(0-60)

¹ Cashco will purchase gauges to the above specs.; ranges may vary from vendor to vendor.

TECHNICAL SPECIFICATIONS

**TABLE 1
APPLICATIONS**

Fluid	Recommended Construction	Trim Designation Number
He, H2	Metal Seat & diaphragm	S1,S0
	Composition Seat & Metal Diaphragm	S36, S9
Air, Inert or Industrial Gases	Metal Seat & Diaphragm	S1
	Metal Seat & Composition Diaphragm	S8
	Composition Seat & Metal Diaphragm	S36
	Composition Seat & Diaphragm	S3, S7
Cryogenic Gases or Liquids	Metal Seat & Diaphragm	S1
	Composition Seat & Metal Diaphragm	S36
Hydrocarbons or Chemicals	Metal Seat & Diaphragm	S1, S0
	Metal Seat & Composition Diaphragm	S8
	Composition Seat & Metal Diaphragm	S36, S9
	Composition Seat & Diaphragm	S3
Sour Gas	Metal Seat and Composition Diaphragm	S8
	Composition Seat and Diaphragm	S3, S7
Oxygen	Composition Seat & Diaphragm	S7
	Composition Seat & Metal Diaphragm	S9, S36
	Metal Seat & Diaphragm	S0, S1
Water and Condensate	Metal Seat & Diaphragm	S1
	Metal Seat & Composition Diaphragm	S8
	Composition Seat & Metal Diaphragm	S36
	Composition Seat & Diaphragm	S3
Saturated Steam (240 psig (16.5 Barg) & lower) ¹	Metal Seat & Diaphragm	S1

¹ Pressure drops above 150 psid (10.3 Bard) may cause accelerated trim and body wear.

**TABLE 2
DESIGN PRESSURE vs. TEMPERATURE RATINGS**

Materials of Construction (Body/Spring Chamber)	End Connection	Option	Design Conditions		
			Inlet & Outlet		
			Pressure		Temperature
			psig (Barg)		°F (°C)
SST/BRZ or SST/SST	NPT	Std	400 (27.6)		-20 to +400
SST/BRZ		-80	600 (41.4)		(-29 to +205)
SST/BRZ or SST/SST	150# Flgd SST	-30 & -34	275 (19.0)		-20 to +100 (-29 to +38)
			235 (16.2)		200 (94)
			215 (14.8)		300 (149)
			195 (13.5)		400 (205)
	300# Flgd SST	-30 & -34	400 (27.6)		-20 to +400 (-29 to +205)
SST/BRZ	300# Flgd SST	-30 + 80 -34 + 80	600 (41.4)		-20 to +200 (-29 to +93)
			560 (38.6)		-20 to +300 (-29 to +149)
			515 (35.5)		-20 to +400 (-29 to +205)
SST/SST	NPT	-36	400 (27.6)		-325 to +100 (-198 to +38)

**TABLE 3
SAFETY RELIEF VALVE SETPOINT PRESSURE**

Range Spring (psig)	Diaphragm Material	Emergency ¹ Over-Pressure (psig)
5-30, 20-80, 70-140, 130-200	ALL	Design Limit from Table 2 or 1.5 x UVRS ² , whichever is least
190-300, 270-400, 360-500 (Opt. -80)	ALL	Design Limit from Table 2 or 1.2 x UVRS ² , whichever is least

¹ "Emergency Over-Pressure" is defined as the level of pressure, which if exceeded, may cause internal mechanical damage.

² UVRS - "Upper Value of Range Spring"; i.e. 130-200 psig (9 -13.8 Barg) range spring, value would be 200 psig (13.8 Barg).

METRIC CONVERSION FACTOR: psig / 14.5 = Barg

**TABLE 4
SAFETY RELIEF VALVE SIZING**

Body Size	Maximum Cv with Valve Plug Wide Open
ALL	0.9 (.78 kv)

**TABLE 5
SST TRIM MATERIAL COMBINATIONS**

Part	SST Trim Designation Number						
	S0	S1	S3 (NACE)	S7 (NACE)	S8 (NACE)	S9	S36
Diaphragm	TFE coated 302 SST	302 SST	Neoprene	Fluorocarbon Elastomer	Neoprene	TFE coated 302 SST	302 SST
Piston	316L SST	316L SST	316L SST	316L SST	316L SST	316L SST	316L SST
Piston O-Ring	TFE	TFE	TFE	TFE	TFE	TFE	TFE
Seat ¹	316L SST	316L SST	TFE	TFE	316L SST	TFE	TFE
Seat Screw	---	---	316 SST	316 SST	---	316 SST	316 SST
Temperature Range °F (°C)	-20 to +400	-325 to +400	-20 to +180	-20 to +400	-20 to +180	-20 to +400	-325 to +400
	(-29 to +205)	(-198 to +205)	(-29 to +82)	(-29 to +205)	(-29 to +82)	(-29 to +205)	(-198 to +205)

¹ The fixed portion of the seat is integral to the body. Indicated seat is the moving portion, and is attached or integral with the piston.

NOTE: Cashco, Inc. does not recommend metal seated trim on any service where the flow will be dead ended down stream of the pressure reducing regulator.

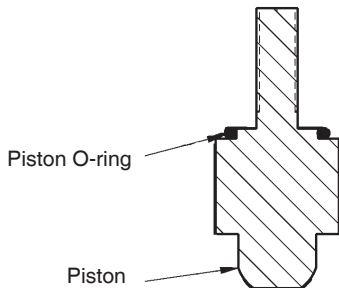

Figure 2: Metal Seat Design

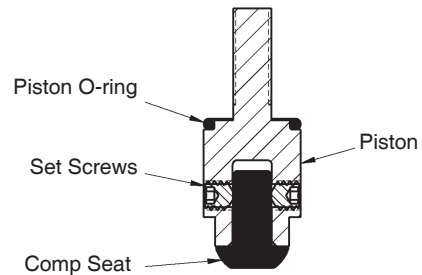

Figure 3: Composition Seat Design

TABLE 6
CAPACITY - Cv
(F_L = 0.95) All Sizes

Setpoint (P ₁) Pressure		METAL DIAPHRAGM					COMPOSITION DIAPHRAGM				
		% Build					% Build				
psig	(Barg)	10%	20%	30%	40%	50%	10%	20%	30%	40%	50%
10	(.69)	.05	.10	.17	.22	.28	.07	.14	.21	.27	.35
25	(1.7)	.09	.18	.27	.35	.43	.11	.22	.34	.44	.54
50	(3.4)	.09	.18	.27	.35	.43	.11	.22	.34	.44	.54
75	(5.2)	.12	.25	.37	.48	.57	.16	.31	.46	.58	.68
100	(6.9)	.08	.17	.25	.33	.41	.10	.20	.30	.40	.50
125	(8.6)	.09	.18	.27	.35	.43	.11	.22	.34	.44	.54
150	(10.3)	.03	.07	.10	.13	.17	.05	.10	.14	.19	.23
200	(13.8)	.07	.14	.21	.28	.35	.09	.17	.27	.35	.43
250	(17.2)	.04	.09	.12	.17	.22	.06	.10	.16	.22	.27
300	(20.7)	.06	.11	.16	.22	.28	.07	.14	.20	.28	.35
350	(24.1)	.13	.27	.40	.52	.62	.17	.32	.47	.60	.70
450	(31.0)	.16	.32	.47	.58	.68	.20	.38	.54	.67	.75
500	(34.5)	.18	.35	.51	.64	.73	.22	.42	.59	.72	.76

Metric Conversion Factor: Cv / 1.16 = kv

TABLE 7
WATER CAPACITY - GPM
S.G. = 1.0 T = 60°F F_L = 0.95
All Sizes - Composition Diaphragm Only

Outlet Pressure psig (Barg)	Setpoint Pressure		1/4" (DN8) Body					3/8" (DN10) Body					1/2" (DN15) Body				
			% Build					% Build					% Build				
	psig	(Barg)	10%	20%	30%	40%	50%	10%	20%	30%	40%	50%	10%	20%	30%	40%	50%
ATM	10	(.69)	0.2	0.5	0.8	1.0	1.4	0.2	0.5	0.8	1.0	1.4	0.2	0.5	0.8	1.0	1.4
	25	(1.7)	0.6	1.2	1.9	2.6	3.3	0.6	1.2	1.9	2.6	3.3	0.6	1.2	1.9	2.6	3.3
	50	(3.4)	0.8	1.7	2.7	3.7	4.7	0.8	1.7	2.7	3.7	4.7	0.8	1.7	2.7	3.7	4.7
	75	(5.2)	1.5	2.9	4.5	5.9	7.2	1.5	2.9	4.5	5.9	7.2	1.5	2.9	4.5	5.9	7.2
	100	(6.9)	1.0	2.1	3.3	4.6	5.9	1.0	2.1	3.3	4.6	5.9	1.0	2.1	3.3	4.6	5.9
	125	(8.6)	1.3	2.6	4.2	5.6	7.2	1.3	2.6	4.2	5.6	7.2	1.3	2.6	4.2	5.6	7.2
	150	(10.3)	0.6	1.3	1.9	2.7	3.3	0.6	1.3	1.9	2.7	3.3	0.6	1.3	1.9	2.7	3.3
	200	(13.8)	1.3	2.6	4.2	5.7	7.2	1.3	2.6	4.2	5.7	7.2	1.3	2.6	4.2	5.7	7.2
	250	(17.2)	1.0	1.7	2.8	4.0	5.1	1.0	1.7	2.8	4.0	5.1	1.0	1.7	2.8	4.0	5.1
300	(20.7)	1.2	2.6	3.8	5.6	7.2	1.2	2.6	3.8	5.6	7.2	1.2	2.6	3.8	5.6	7.2	
10 (0.69)	25	(1.7)	0.5	1.0	1.6	2.2	2.8	0.5	1.0	1.6	2.2	2.8	0.5	1.0	1.6	2.2	2.8
	50	(3.4)	0.7	1.6	2.5	3.4	4.4	0.7	1.6	2.5	3.4	4.4	0.7	1.6	2.5	3.4	4.4
	75	(5.2)	1.4	2.8	4.3	5.7	6.9	1.4	2.8	4.3	5.7	6.9	1.4	2.8	4.3	5.7	6.9
	100	(6.9)	1.0	2.1	3.3	4.6	5.9	1.0	2.1	3.3	4.6	5.9	1.0	2.1	3.3	4.6	5.9
	125	(8.6)	1.2	2.6	4.2	5.7	7.2	1.2	2.6	4.2	5.7	7.2	1.2	2.6	4.2	5.7	7.2
	150	(10.3)	0.6	1.3	1.9	2.7	3.3	0.6	1.3	1.9	2.7	3.3	0.6	1.3	1.9	2.7	3.3
	200	(13.8)	1.3	2.6	4.2	5.7	7.2	1.3	2.6	4.2	5.7	7.2	1.3	2.6	4.2	5.7	7.2
	250	(17.2)	1.0	1.7	2.8	4.0	5.1	1.0	1.7	2.8	4.0	5.1	1.0	1.7	2.8	4.0	5.1
300	(20.7)	1.2	2.6	3.8	5.6	7.2	1.2	2.6	3.8	5.6	7.2	1.2	2.6	3.8	5.6	7.2	
25 (1.7)	50	(3.4)	0.6	1.3	2.2	3.0	3.8	0.6	1.3	2.2	3.0	3.8	0.6	1.3	2.2	3.0	3.8
	75	(5.2)	1.2	2.5	3.9	5.2	6.4	1.2	2.5	3.9	5.2	6.4	1.2	2.5	3.9	5.2	6.4
	100	(6.9)	0.9	1.9	3.1	4.3	5.6	0.9	1.9	3.1	4.3	5.6	0.9	1.9	3.1	4.3	5.6
	125	(8.6)	1.2	2.5	4.0	5.4	6.9	1.2	2.5	4.0	5.4	6.9	1.2	2.5	4.0	5.4	6.9
	150	(10.3)	0.6	1.2	1.8	2.6	3.3	0.6	1.2	1.8	2.6	3.3	0.6	1.2	1.8	2.6	3.3
	200	(13.8)	1.3	2.5	4.1	5.6	7.1	1.3	2.5	4.1	5.6	7.1	1.3	2.5	4.1	5.6	7.1
	250	(17.2)	1.0	1.7	2.8	4.0	5.1	1	1.7	2.8	4.0	5.1	1.0	1.7	2.8	4.0	5.1
300	(20.7)	1.2	2.6	3.8	5.6	7.2	1.2	2.6	3.8	5.6	7.2	1.2	2.6	3.8	5.6	7.2	

Metric Conversion Factor: GPM X 3.785 = LPM

TABLE 8
AIR CAPACITY - SCFH
S.G. = 10 T = 60°F F_L

All Sizes - Composition Diaphragm Only

Outlet Pressure psig (barg)	Setpoint Pressure psig (barg)	1/4" (DN8) Body					3/8" (DN10) Body					1/2" (DN15) Body				
		10%	20%	30%	40%	50%	10%	20%	30%	40%	50%	10%	20%	30%	40%	50%
ATM	10 (.69)	60	130	210	270	370	60	130	210	270	370	60	130	210	270	370
	25 (1.7)	160	350	570	770	1000	160	350	570	770	1000	160	350	570	770	1000
	50 (3.4)	270	580	960	1320	1710	270	580	960	1320	1710	270	580	960	1320	1710
	75 (5.2)	550	1150	1830	2460	SONIC	550	1150	1830	2460	3060	550	1150	1830	2460	3060
	100 (6.9)	440	950	1540	2190	SONIC	440	950	1540	2190	2910	440	950	1540	2190	2910
	125 (8.6)	590	1280	2130	SONIC	SONIC	590	1280	2130	2960	3870	590	1280	2130	2960	3870
	150 (10.3)	320	690	1040	1510	1950	320	690	1040	1510	1950	320	690	1040	1510	1950
	200 (13.8)	750	1530	2630	SONIC	SONIC	750	1530	2630	3660	4800	750	1530	2630	3660	4800
	250 (17.2)	620	1120	1930	2850	HI BUILD	620	1120	1930	2850	HI BUILD	620	1120	1930	2850	HI BUILD
	300 (20.7)	860	1860	2870	HI BUILD	HI BUILD	860	1860	2870	HI BUILD	HI BUILD	860	1860	2870	HI BUILD	HI BUILD
350 (24.1)	2410	SONIC	HI BUILD	HI BUILD	HI BUILD	2410	4940	HI BUILD	HI BUILD	HI BUILD	2410	4940	HI BUILD	HI BUILD	HI BUILD	
450 (31.0)	SONIC	SONIC	HI BUILD	HI BUILD	HI BUILD	3620	SONIC	HI BUILD	HI BUILD	HI BUILD	3620	7480	HI BUILD	HI BUILD	HI BUILD	
25 (1.7)	50 (3.4)	260	550	900	1240	1610	260	550	900	1240	1610	260	550	900	1240	1610
	75 (5.2)	540	1140	1810	2430	3030	540	1140	1810	2430	3030	540	1140	1810	2430	3030
	100 (6.9)	440	950	1530	2190	2910	440	950	1530	2190	2910	440	950	1530	2190	2910
	125 (8.6)	590	1280	2130	2960	3870	590	1280	2130	2960	3870	590	1280	2130	2960	3870
	150 (10.3)	320	690	1040	1510	1950	320	690	1040	1510	1950	320	690	1040	1510	1950
	200 (13.8)	750	1530	2630	3660	4800	750	1530	2630	3660	4800	750	1530	2630	3660	4800
	250 (17.2)	620	1120	1930	2850	HI BUILD	620	1120	1930	2850	HI BUILD	620	1120	1930	2850	HI BUILD
	300 (20.7)	860	1860	2870	HI BUILD	HI BUILD	860	1860	2870	HI BUILD	HI BUILD	860	1860	2870	HI BUILD	HI BUILD
	350 (24.1)	2410	4940	HI BUILD	HI BUILD	HI BUILD	2410	4940	HI BUILD	HI BUILD	HI BUILD	2410	4940	HI BUILD	HI BUILD	HI BUILD
	450 (31.0)	3620	7480	HI BUILD	HI BUILD	HI BUILD	3620	7480	HI BUILD	HI BUILD	HI BUILD	3620	7480	HI BUILD	HI BUILD	HI BUILD
50 (3.4)	75 (5.2)	460	960	1530	2060	2560	460	960	1530	2060	2560	460	960	1530	2060	2560
	100 (6.9)	420	900	1450	2060	2740	420	900	1450	2060	2740	420	900	1450	2060	2740
	150 (10.3)	320	680	1030	1500	1930	320	680	1030	1500	1930	320	680	1030	1500	1930
	200 (13.8)	750	1530	2630	3650	4790	750	1530	2630	3650	4790	750	1530	2630	3650	4790
	250 (17.2)	620	1120	1930	2850	HI BUILD	620	1120	1930	2850	HI BUILD	620	1120	1930	2850	HI BUILD
	300 (20.7)	860	1860	2870	HI BUILD	HI BUILD	860	1860	2870	HI BUILD	HI BUILD	860	1860	2870	HI BUILD	HI BUILD
	350 (24.1)	2410	4940	HI BUILD	HI BUILD	HI BUILD	2410	4940	HI BUILD	HI BUILD	HI BUILD	2410	4940	HI BUILD	HI BUILD	HI BUILD
	450 (31.0)	3620	7480	HI BUILD	HI BUILD	HI BUILD	3620	7480	HI BUILD	HI BUILD	HI BUILD	3620	7480	HI BUILD	HI BUILD	HI BUILD
100 (6.9)	125 (8.6)	410	890	1470	2040	2670	410	890	1470	2040	2670	410	890	1470	2040	2670
	150 (10.3)	270	580	870	1270	1640	270	580	870	1270	1640	270	580	870	1270	1640
	200 (13.8)	700	1450	2480	3440	4520	700	1450	2480	3440	4520	700	1450	2480	3440	4520
	250 (17.2)	600	1090	1880	2780	HI BUILD	600	1090	1880	2780	HI BUILD	600	1090	1880	2780	HI BUILD
	300 (20.7)	850	1840	2840	HI BUILD	HI BUILD	850	1840	2840	HI BUILD	HI BUILD	850	1840	2840	HI BUILD	HI BUILD
	350 (24.1)	2400	4920	HI BUILD	HI BUILD	HI BUILD	2400	4920	HI BUILD	HI BUILD	HI BUILD	2400	4920	HI BUILD	HI BUILD	HI BUILD
150 (10.3)	450 (31.0)	3620	7480	HI BUILD	HI BUILD	HI BUILD	3620	7480	HI BUILD	HI BUILD	HI BUILD	3620	7480	HI BUILD	HI BUILD	HI BUILD
	200 (13.8)	570	1160	1980	2760	3620	570	1160	1980	2760	3620	570	1160	1980	2760	3620
	250 (17.2)	550	990	1710	2520	HI BUILD	550	990	1710	2520	HI BUILD	550	990	1710	2520	HI BUILD
	300 (20.7)	810	1750	2700	HI BUILD	HI BUILD	810	1750	2700	HI BUILD	HI BUILD	810	1750	2700	HI BUILD	HI BUILD
	350 (24.1)	2330	4780	HI BUILD	HI BUILD	HI BUILD	2330	4780	HI BUILD	HI BUILD	HI BUILD	2330	4780	HI BUILD	HI BUILD	HI BUILD
	450 (31.0)	3580	7410	HI BUILD	HI BUILD	HI BUILD	3580	7410	HI BUILD	HI BUILD	HI BUILD	3580	7410	HI BUILD	HI BUILD	HI BUILD

NOTES: Where "SONIC" is indicated within the above capacity tables, outlet velocity with Schedule 40 pipe has reached sonic velocity of 1118 fps. Additional flow cannot be obtained and pipeline velocity is in excess of customary pipe velocity design limits. Maximum flow will be approximately the last indicated value in the column above "SONIC".

Where "HI BUILD" is indicated, the pressure build exceeds established limits in Technical Bulletin.

Metric Conversion Factor: SCFH / 35.31 = Sm³/Hr; SCFH / 37.32 = Nm³/Hr

TABLE 9
STEAM CAPACITY - LBS/HR
S.G. = Actual T = Saturated F_L = 0.95
All Sizes - Metal Diaphragm Only

Outlet Pressure psig (Barg)	Setpoint Pressure		1/4" Body					3/8" Body					1/2" Body				
			% Build					% Build					% Build				
	psig	(Barg)	10%	20%	30%	40%	50%	10%	20%	30%	40%	50%	10%	20%	30%	40%	50%
ATM	10	(.69)	2	4	7	10	13	2	4	7	10	13	2	4	7	10	13
	25	(1.7)	7	13	21	28	35	7	13	21	28	35	7	13	21	28	35
	50	(3.4)	11	23	35	47	59	11	23	35	47	59	11	23	35	47	59
	75	(5.2)	20	43	66	89	109	20	43	66	89	109	20	43	66	89	109
	100	(6.9)	17	38	57	78	100	17	38	57	78	100	17	38	57	78	100
	125	(8.6)	23	48	75	101	128	23	48	75	101	128	23	48	75	101	128
	150	(10.3)	9	22	33	44	60	9	22	33	44	60	9	22	33	44	60
	200	(13.8)	28	57	89	124	160	28	57	89	124	160	28	57	89	124	160
10 (.69)	25	(1.7)	6	12	19	25	32	6	12	19	25	32	6	12	19	25	32
	50	(3.4)	11	22	34	45	57	11	22	34	45	57	11	22	34	45	57
	75	(5.2)	20	42	65	87	106	20	42	65	87	106	20	42	65	87	106
	100	(6.9)	17	38	57	78	100	17	38	57	78	100	17	38	57	78	100
	125	(8.6)	23	48	75	101	128	23	48	75	101	128	23	48	75	101	128
	150	(10.3)	9	22	33	44	60	9	22	33	44	60	9	22	33	44	60
	200	(13.8)	28	57	89	124	160	28	57	89	124	160	28	57	89	124	160
	240	(16.6)	19	44	61	89	119	19	44	61	89	119	19	44	61	89	119
25 (1.7)	50	(3.4)	10	20	31	42	53	10	20	31	42	53	10	20	31	42	53
	75	(5.2)	19	41	64	85	104	19	41	64	85	104	19	41	64	85	104
	100	(6.9)	17	37	56	76	97	17	37	56	76	97	17	37	56	76	97
	125	(8.6)	23	47	73	98	125	23	47	73	98	125	23	47	73	98	125
	150	(10.3)	9	22	33	44	59	9	22	33	44	59	9	22	33	44	59
	200	(13.8)	28	57	89	124	160	28	57	89	124	160	28	57	89	124	160
50 (3.4)	240	(16.6)	19	44	61	89	119	19	44	61	89	119	19	44	61	89	119
	75	(5.2)	17	36	55	74	90	17	36	55	74	90	17	36	55	74	90
	100	(6.9)	16	35	53	72	92	16	35	53	72	92	16	35	53	72	92
	125	(8.6)	22	46	72	96	122	22	46	72	96	122	22	46	72	96	122
	150	(10.3)	9	21	32	43	57	9	21	32	43	57	9	21	32	43	57
100 (6.9)	200	(13.8)	27	56	87	120	155	27	56	87	120	155	27	56	87	120	155
	240	(16.6)	18	43	60	88	117	18	43	60	88	117	18	43	60	88	117
	125	(8.6)	17	36	56	75	95	17	36	56	75	95	17	36	56	75	95
	150	(10.3)	8	19	28	38	51	8	19	28	38	51	8	19	28	38	51
100 (6.9)	200	(13.8)	26	54	83	115	149	26	54	83	115	149	26	54	83	115	149
	240	(16.6)	18	42	58	85	114	18	42	58	85	114	18	42	58	85	114

Metric Conversion Factor: LBS/HR X 0.4536 = KG/HR

DIMENSIONS AND WEIGHTS

ENGLISH UNITS (Inches)									
Body Size	A	B	C	D	E	F	G	H	Ship Weight
Angle 1/4",3/8",1/2"	-	-	-	4.94	-	-	2.50 ***	1.06	3 lbs.
Globe 1/2"	-	-	-	5.25	-	-	3.00	.75	
-2 (Handwheel)	-	-	-	5.44 **	-	-	-	-	
-20(Dome Load)	-	-	-	2.25 **	-	-	-	-	
-22 (Panel Mount)	-	-	-	5.44 **	2.38	2.31	-	-	
-30 (Angle) *	-	4.00	4.00	-	-	-	-	-	8 lbs.
-34 (Globe) *	14.00	7.00	-	-	-	-	-	-	10 lbs.
-80 (High Outlet Pressure)	-	-	-	7.25 **	-	-	-	-	4 lbs.
-2+80	-	-	-	9.75 **	-	-	-	-	
METRIC UNITS (mm)									
Body Size	A	B	C	D	E	F	G	H	Ship Weight
Angle (DN8, DN10, DN15)	-	-	-	125	-	-	64 ***	27	1.36 kgs.
Globe (DN15)	-	-	-	134	-	-	76	19	
-2 (Handwheel)	-	-	-	138 **	-	-	-	-	
-20 (Dome Load)	-	-	-	57 **	-	-	-	-	
-22 (Panel Mount)	-	-	-	138 **	61	59	-	-	3.63 kgs.
-30 (Angle) *	-	101	101	-	-	-	-	-	4.54 kgs.
-34 (Globe) *	356	178	-	-	-	-	-	-	1.81 kgs.
-80 (High Outlet Pressure)	-	-	-	184 **	-	-	-	-	1.81 kgs.
-2+80	-	-	-	248 **	-	-	-	-	

* Only 1/2" (DN15) body size is available with Opt-30 and Opt-34 flanged end connections.

** When specified with Globe Design 1/2" size add 0.31" (8 mm).

***Angle Design 1/2" (DN15) body size - dimension = 3.00"

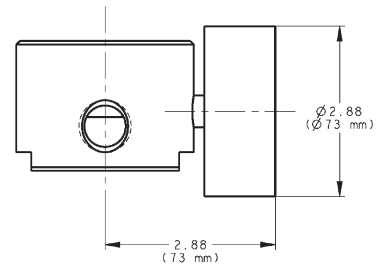
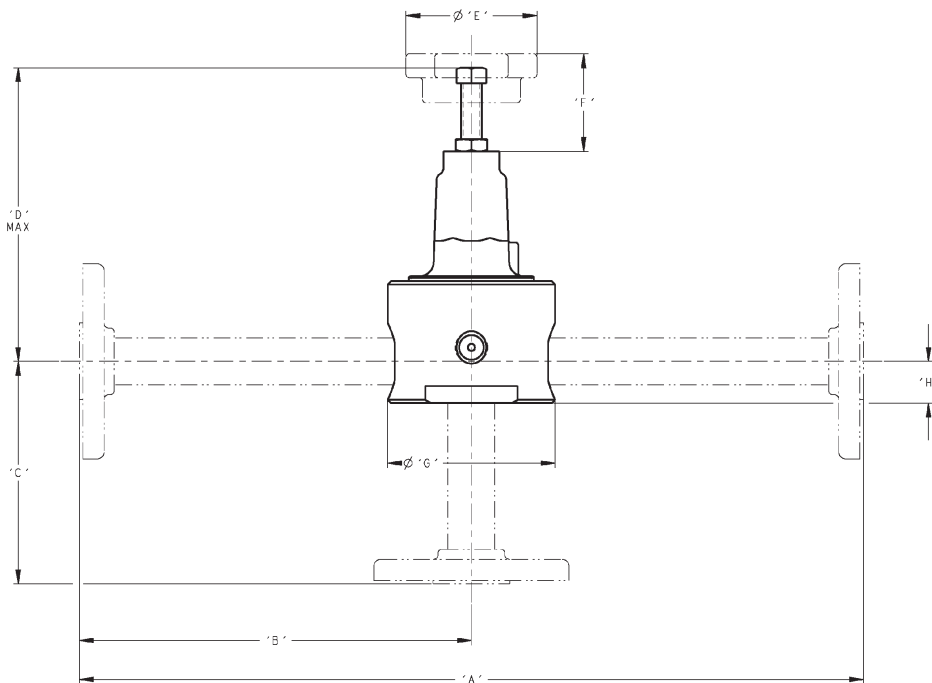

Opt-86: Inlet Pressure Gauge

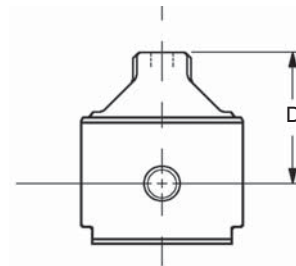

Opt-20: Dome Load

NOTES

The contents of this publication are presented for informational purposes only, and while every effort has been made to ensure their accuracy, they are not to be construed as warranties or guarantees, express or implied, regarding the products or services described herein or their use or applicability. We reserve the right to modify or improve the designs or specifications of such product at any time without notice. Cashco, Inc. does not assume responsibility for the selection, use or maintenance of any product. Responsibility for proper selection, use and maintenance of any Cashco, Inc. product remains solely with the purchaser.

MODEL 2171 PRODUCT CODER 02/19/16

An "X" in POS 12 followed by a 5-digit control number overrides remaining selections.



POSITION 2 - GASKET * & SERVICE			
Service	Options	CODE	
Basic (Above -20°F(-29°C))	Std. Non-Oxygen	—	B
	Primarily for Oxygen	-45	D
Cryogenic -325 to +100°F (-198 to 38°C)	All	-36**	C

*Refer to Tech Bulletin for temperature limits.
**Cryo Const. includes Special Cleaning #S-1134 (Opt.-55).

POSITION 3 - SIZES		
In	(DN)	CODE
Angle Design (Two side inlets with bottom outlet)		
1/4"	(8)	2
3/8"	(10)	3
1/2"	(15)	4
Globe Design (Side inlet- Side outlet)		
1/2"	(15)	7
3/4" *	(20)	5
1" *	(25)	6

* 1/2" size body w/ Reducing Flanges.
3/4" & 1" Size not available in NPT.

POSITION 5 - BODY & SPRING CHAMBER MATERIALS	
Body/Sp. Ch.	CODE
SST / BRZ	8
SST / SST *	A

* Required for Opt-36.

POSITION 6 & 7 - TRIM	
Desig. No	CODE
S0	S0
S1*	S1
S3 **	SF
S7 **	SG
S8 **	S8
S9	SH
S36*	SJ

* Suitable for Opt-36.
** Suitable for NACE.

POSITION 10 - END CONNECTIONS		
Opt.	Type	CODE
Angle & Globe	NPT	1
-30 * Angle Design Select Code "4" from Position 3.	150# Flgs.	A
	300# Flgs.	B
	DIN (PN40)	D
-34 * Globe Design Select Code "5", "6" or "7" from Position 3.	150# Flgs.	V
	300# Flgs.	W
	DIN (PN40)	Z

* 1/2" (DN15) Body Size,
2 connections ONLY.

POSITION 12 - TRIM VARIATIONS		
Description	Option	CODE
No Option	--	0
For Special Construction Contact Cashco for Special Product Code.	SPQ	X

POSITION 13 - FEATURE OPTIONS		
Description	Option	CODE
No Option	-	0
Handwheel *	-2	2
Panel Mounting - Handwheel included *	-22	C

* Not available with Cryogenic Construction

POSITION 11 - RANGE SPRINGS				
Spring Chamber Option	Range Spring		STD	Opt -36 ‡
	Psig	(Barg)	CODE	CODE
Std.	5-30	(.34-2.1)	1	A
	20-80	(1.4-5.5)	2	B
	70-140	(4.8-9.7)	3	C
	130-200	(9.0-13.8)	4	D
Opt-80 *	190-300	(13.1-20.7)	5	
	270-400	(18.6-27.6)	6	
	360-500	(24.8-34.5)	7	
Opt-20	No Spring Dome Loaded		Y	

* Opt-80 for High Outlet Pressure construction. Non- NACE.
‡ SST spring.

POSITION 14 - SPRING CHAMBER OPTIONS		
Description	Option	CODE
No Option	-	0
Vent Tap.	-25	D
Vent Screen (includes Opt-25).	-25S	H

POSITION 15 - BODY OPTIONS		
Description	Option	CODE
No Option	-	0
Inlet Gauge Tap - 1/4" NPT (No Gauge).	-85	V
Inlet Pressure Gauge (Includes Opt-85) *.	-86	Y

* NOT available with Opt-36 or Opt-55.

POSITION 16 - CERTIFICATE OPTIONS		
Description	Option	CODE
No Option	-	0
NACE Const. SST/SST/XX Per MR0175, S3, S7, S8 Trims.	-40SST	K
Special Cleaning: Per Cashco Spec #S-1134. Suitable for oxygen service.	-55	M
Special Cleaning: Per Cashco Spec #S-1542.	-56	N

Cashco, Inc.
P.O. Box 6
Ellsworth, KS 67439-0006
PH (785) 472-4461
Fax. # (785) 472-3539
www.cashco.com
email: sales@cashco.com
Printed in U.S.A. 2171-TB

Cashco GmbH
Handwerkerstrasse 15
15366 Hoppegarten, Germany
PH +49 3342 30968 0
Fax. No. +49 3342 30968 29
www.cashco.com
email: germany@cashco.com

Cashco do Brasil, Ltda.
Al.Venus, 340
Indaiatuba - Sao Paulo, Brazil
PH +55 11 99677 7177
Fax. No.
www.cashco.com
email: brazil@cashco.com